



kerlite[®]
Technical manual

COTTODESTE
Nuove Superfici

Lightness and versatility

Imagine a ceramic material that can encompass in a thickness of only 3 mm all the technical properties of conventional porcelain stoneware and extend its fields of use also to furnishing. The result is a new ceramic mineral that has made ease-of-use and versatility its strong points. Resistant, flat, easy to cut, drill, install and clean, KERLITE is offered in the brand new 300x100 cm size, with two thickness options to offer a complete range for any intended use: 3 mm (KERLITE 3MM) for interior and exterior walls, 3.5 mm (KERLITE PLUS) for floors. Inspired by the needs of contemporary architecture, KERLITE launches the age of global coverings.



 <p>The advantage of being unique</p>	<p>resistant</p> <p>KERLITE PLUS resists a bending stress of 1000 Newton</p>	<p>large</p> <p>A range of 10 sizes, up to 3 x 1 metres</p>
<p>planare</p> <p>la superficie è sempre perfettamente piana</p>	<p>thin and light</p> <p>A thickness of 3 mm and a weight of only 7 kg/m²</p>	<p>easy</p> <p>To cut, drill and install</p>
<p>reliable</p> <p>It has been chosen for many prestigious projects all over the world</p>	<p>guaranteed</p> <p>20-year guarantee</p>	<p>eco friendly</p> <p>-66% raw material required</p>

Table of contents

01	KERLITE	4
1.1 -	What is KERLITE	4
1.2 -	Available types: KERLITE and KERLITE PLUS	4
02	KERLITE and KERLITE PLUS: Which and Why	5
03	Working with KERLITE and KERLITE PLUS	6
3.1 -	Handling	6
3.2 -	Drilling, cutting and edge-finishing	8
3.2.1 -	Manual processing	8
3.2.2 -	Processing with automatic machines	10
04	Installing KERLITE and KERLITE PLUS	12
4.1 -	Preparing the support	12
4.1.1 -	Supporting material: requirements	12
4.1.2 -	Supporting material: instructions for particular situations	13
4.1.3 -	Supporting material: instructions for special construction systems	14
4.1.4 -	Supporting material: instructions for installing in accordance to "the rules of the trade"	15
4.2 -	Recommended adhesives	16
4.3 -	Instructions for installation	18
4.3.1 -	Adhesives: single-layer method / double-layer method	18
4.3.2 -	Laying the slab	18
4.3.3 -	Grouting joints and expansion joints	19
05	Cleaning and care	20
06	Connecting profiles, finishing and trim pieces	22
07	Making corners during installation	24
7.1 -	Solution 1	24
7.2 -	Solution 2	25
08	Technical information	26
8.1 -	Technical Characteristics	26
8.2 -	Texts for tenders	30
8.3 -	Packages	31
09	Handy addresses	32
	Adhesives attachment	34

1.1 - What is KERLITE

Produced by means of ground-breaking technology, KERLITE is manufactured in 300x100 cm slabs, with a thickness of 3 mm, using a mixture for porcelain stoneware composed of top quality clay and raw materials. It is pressed at a force of 15,000 tons. Firing takes place in innovative and ecological kilns that are the result of the research and know-how of Panariagroup. Single slabs of KERLITE have a thickness of only 3 mm: this makes them flexible, light and extremely easy to handle. The minimal thickness is the **striking feature**, which makes the product suitable for a variety of different applications.

1.2 - Available types: KERLITE and KERLITE PLUS

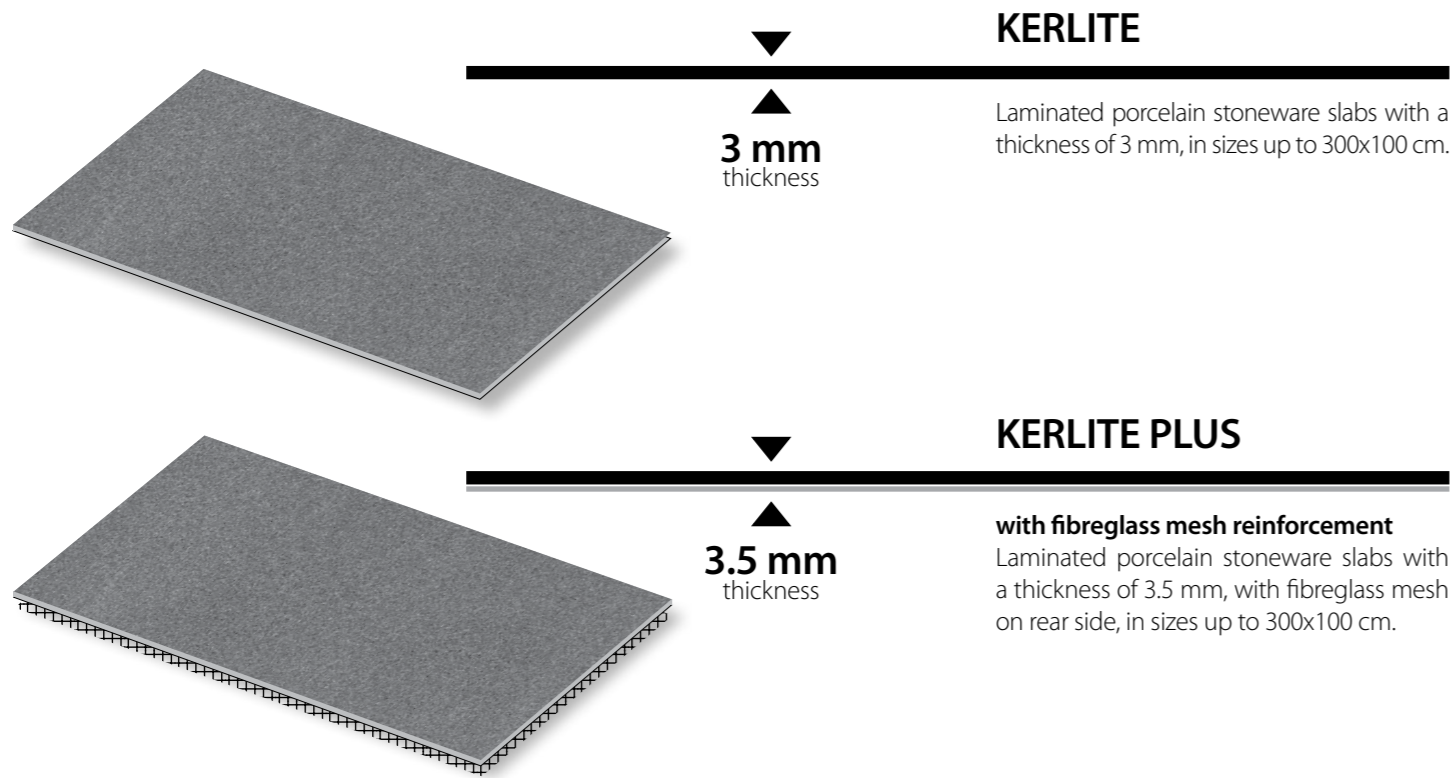

KERLITE and KERLITE PLUS: Which and Why

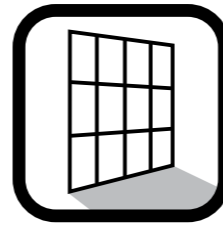

Wall installation

 Interiors	In situations where holes and/or cuts are not necessary.	KERLITE
	In situations where holes and/or cuts are necessary.	KERLITE PLUS
 Exteriors	In situations where holes and/or cuts are not necessary and with sizes up to 100 x 100 cm.	KERLITE
	In situations where holes and/or cuts are necessary and/or for large sizes.	KERLITE PLUS



To make the most of KERLITE, choose the kind best suiting the intended use and project requirements.

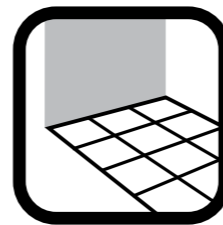

Floor installation

 Interiors	In any situation with the exception of areas subject to heavy loads (e.g. trolleys with hard wheels).	KERLITE PLUS
 Exteriors	Upon condition that surfaces are sheltered (e.g. loggias, covered balconies, etc.) and made totally impervious.	KERLITE PLUS

Working with KERLITE and KERLITE PLUS

3.1 - Handling

Owing to their lightness, all types of KERLITE are much easier to handle and transport than slabs of marble, granite and natural stone, which are much thicker and therefore much heavier. With an identical weight, the number of square metres transported is four times greater. The weight of a 100x100 cm slab is only 7.4 kg for the normal version and 7.8 kg for the PLUS version with fibreglass mesh.

HANDLING WHOLE SLABS (300x100 cm) OF KERLITE AND KERLITE PLUS



Fig.1 - 300x100 cm slabs of KERLITE and KERLITE PLUS can be lifted by one person only. Lift the slab with open hands. Slowly raise the longer side so as to eliminate the suction effect, due to contact with the underlying slab, and ensure a good grip.

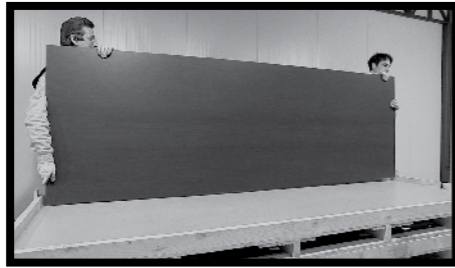

Fig.2 - You can now guide the slab to its upright position, keeping it as straight as possible.



Fig.3 - When the slab is upright, hold it from its top edge and shift it keeping it straight and upright. This operation should be performed with the aid of a second person.



Fig.4/5 - All versions of KERLITE slabs, of size 300x100 cm, can be handled by two persons, using a special frame. Fasten the frame to the slab when it is still on the pallet. Now raise the frame and slab to eliminate the suction effect.





Owing to their lightness, all types of KERLITE are much easier to handle and transport than slabs of marble, granite and natural stone, which are much thicker and therefore much heavier.

Frame

To safely handle slabs of KERLITE in the 300x100 cm size, a special frame is available upon demand. It is made of aluminium and features suction cups. It is ideal for installing on scaffolding at a height of over 2 metres.

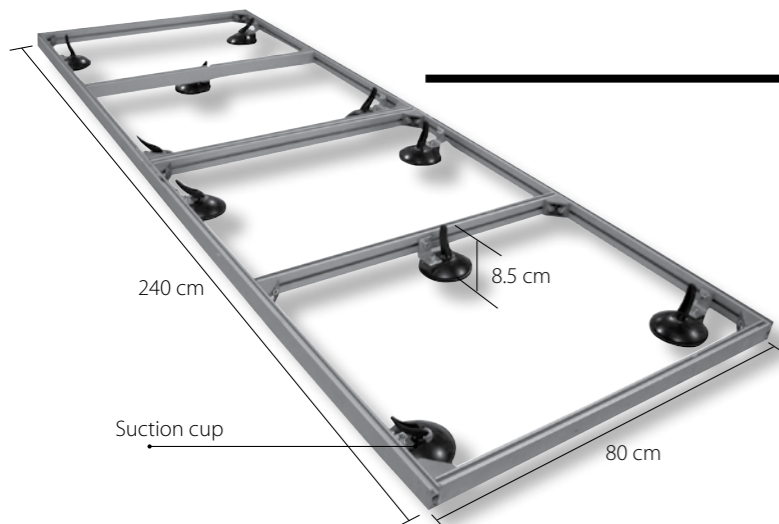

STORAGE OF WHOLE SLABS (300x100 cm)

All versions of KERLITE slabs (300x100 cm) can be stored either in vertical or horizontal position. If you place one slab on top of the other, make sure that each slab is clean and that the surface the slabs are resting on is flat.

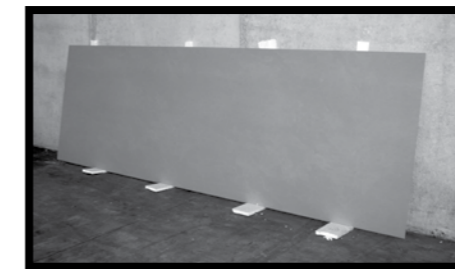

Fig.6 - As concerns the upright position, place the long side of the slab on a wooden plank.

HANDLING PACKAGES CONTAINING 300x100 cm SLABS

Lifting and handling palletised packages with forklift trucks:



Fig.7 - To take on pallets from their long side, position the forks at a distance of at least 1 metre the one from the other, perpendicular to the long side of the pallet and at the centre of the latter. Forks must be supporting the entire surface of the pallet.



Fig.8 - To take on pallets from their short side (e.g. when unloading containers), you must use forks with a length of at least 2.5 metres to guarantee a sufficiently long supporting surface and therefore protection of the package and its contents.

3.2 - Drilling, cutting and edge-finishing

A striking feature of KERLITE is its extreme ease-of-installation: this material can be easily cut, shaped and drilled both by tile layers and by specialised persons (stone cutters, glass-workers, etc.) using automatic machines and tools for porcelain stoneware, glass and marble.

If you have to drill holes for pipes or perform cuts for switch boxes or other items, you must choose KERLITE PLUS.



A striking feature of KERLITE is its extreme ease-of-installation.

3.2.1 - Manual processing

PREPARATION

It is essential to work on a flat and clean surface. For instance, you can use the cover of the pallet of the 300x100 cm slab.

CUTTING WITH A GLASS CUTTER OR MANUAL TILE CUTTER

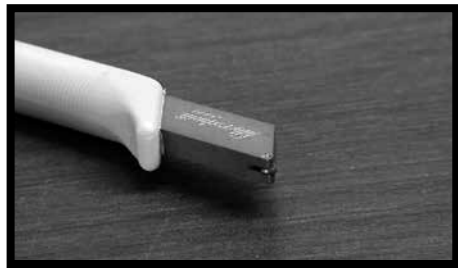

Fig.9 - You can obtain excellent results in terms of shape and clear cuts by engraving all versions of KERLITE with Silberschnitt 2000 special glass cutters made by **Bohle Italia** or with the manual tile cutter made by **Würth**. To achieve good cuts, never detach the glass cutter from the slab throughout the entire cutting operation.



Fig.10 - To ensure that the engraving is as straight as possible, you may use aluminium levelling rods of the type commonly used by brick layers.



Fig.11 - After engraving, it is sufficient to bend the slab to detach the two pieces.

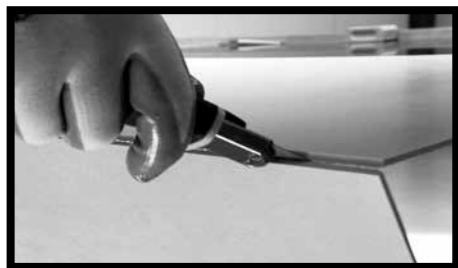

Fig.12 - As far as KERLITE PLUS is concerned, after engraving the ceramic part and splitting the slab, complete the operation by cutting the fiberglass mesh with a standard cutter.



Fig.13 - A practical tool for cutting is the tile cutter ruler (for instance Keracut from **Sigma** or Free-cut from **Raimondi**). As far as KERLITE PLUS is concerned, after engraving the ceramic part and splitting the slab, complete the operation by cutting the fiberglass mesh with a standard cutter (**Fig.12**).

CUTTING WITH DIAMOND DISCS

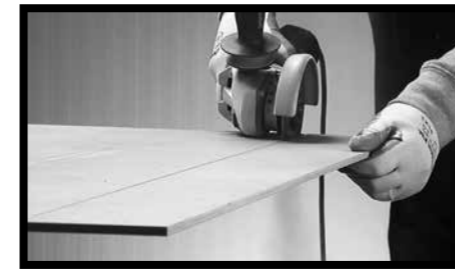

Fig.14 - All versions of KERLITE can be cut using diamond discs fitted onto hand-held electrical grinding machines. Disc rotation speed must be high (>10000 RPM) and speed at which tool is pushed low (< 1 m/min). Depending on the type of disc and the length of the cut, it may be necessary to cool the disc with water. Recommended discs are the thin types generally used for cutting porcelain stoneware. The advantages of this type of cut include ease-of-execution and the possibility to cut during installation.

DRILLING



Fig.15 - As far as manual drilling is concerned, use tungsten bits with a diameter up to 10 mm, fitted to electric drills or battery-operated screwdrivers.



Fig.16/17 - As an alternative, you can use cutting discs fitted to angle grinders, electrical drills or battery-operated screwdrivers.



When using these tools:

- cool the point drilled with water;
- do not exert too much pressure and bear in mind the resistance of the type of laminated stoneware you are working on;
- if you are using tungsten bits, start drilling at a low speed;
- if you are using a drill or a screwdriver, do not select hammering mode.

EDGE-FINISHING



Fig.18 - Edges can be finished by hand using abrasive diamond sponges or emery paper. With a light passage on the side of the slab, you can obtain a slightly rounded-off edge or with repeated passages a bevelled effect



Fig.19 - The same results can be obtained with sanding discs fitted onto angle grinders.

3.2.2 - Processing with automatic machines



If you have to drill holes for pipes or perform cuts for switch boxes or other items, you must choose KERLITE PLUS.

Irrespective of the system adopted, the underlying surface must be perfectly flat to prevent minor vibration and movements of the slab that could lead to breakage or damage to the finish. It is recommended to use diamond tools for porcelain stoneware, in good working order.

If you have to drill holes for pipes or perform cuts for switch boxes or other items, you must choose KERLITE PLUS. To obtain internal corners, round off the vertex of the corner using bits with a radius of at least 5 mm that reduce the risk of breakage. It is recommended to perform a few tests before cutting so as to set up the machine in the best manner possible. Operating parameters provided in this guide are to be considered as **indicative** and must be perfected and checked by the user based on the material used and the operations to perform.

ENGRAVING



Fig.20 - KERLITE and KERLITE PLUS can be cut by engraving. This operation must be performed on a cutting bench and on the front face of the slab. As far as KERLITE PLUS is concerned, if this operation cannot be performed automatically on the cutting bench, the fibreglass mesh must be cut by hand with a cutter. Move the cutting tool forward at a speed of 10 m/min. and in any case at a suitable speed for the finish and colour of the slab. Apply an average pressure of about 1.2 bar. For slabs with light colours, you must exert a pressure of about 1.5 bar.

CUTTING WITH A DISC



Fig.21 - All versions of KERLITE can be cut with diamond discs. Use discs made especially for porcelain stoneware and in good working order. Disc rotation speed must be high (>2000 RPM) and speed at which tool is pushed low (from 0.5 to 1 m/min.) Depending on the type of disc and the length of the cut, it may be necessary to cool the disc with water. Reduce speed at the start and at the end of the cut.

CUTTING WITH A NUMERIC CONTROL MACHINE



Fig.22 - All versions of KERLITE can be cut with numeric control machines. Cutter rotation speed ranges from 12000 to 18000 RPM. The cutter must be pushed forward at a speed ranging from 0.5 to 1 m/min.

CUTTING WITH A WATER JET MACHINE



Fig.23 - All versions of KERLITE can be cut with water jet cutting machines. Adopt a speed ranging from 2 to 3 m/min.

DRILLING WITH A NUMERIC CONTROL MACHINE

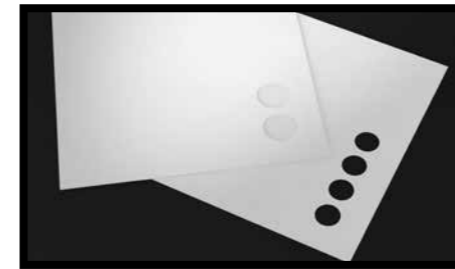

Fig.24 - All versions of KERLITE can be drilled with numeric control machines. Drill a preliminary hole using a diamond drill bit. If necessary, use a cutter to enlarge the hole to the requested size. Use a bit with a diameter ranging from 4 to 8 mm. Operating speed is 40 mm/min. with spindle rotation of 900 RPM. When using these tools: cool the point drilled with water; start drilling at a low speed; never exert too much pressure and bear in mind the resistance of the type of KERLITE you are working on.

DRILLING WITH A WATER JET MACHINE



Fig.25 - All versions of KERLITE can be drilled with water jet cutting machines. With water jet machines, you can obtain holes with a smaller diameter with respect to those possible with a numeric control machine. Operating speed must range from 2 to 3 m/min.

EDGE POLISHING



Fig.26 - To shape and polish the edge of the slab, use diamond/abrasive discs, which are suitable for obtaining an edge of the shape and size requested. Then use a polishing disc. Different discs are available for obtaining different edge finishes. Operating speed must be tested beforehand.

45° CUT



Fig.27 - To obtain 45° cuts, use 45° diamond discs. In this manner, you can join two slabs of KERLITE to create a corner. The corner must be bevelled. Different discs are available for obtaining a variety of edge finishes. Operating speed must be tested beforehand.

BEVELLING

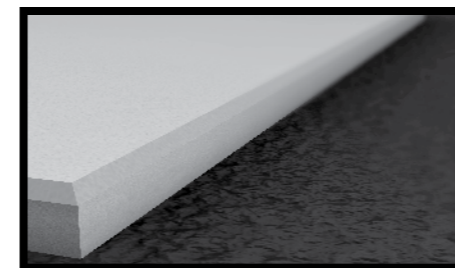

Fig.28 - All versions of KERLITE can be bevelled. To obtain curved edges, use a numeric control machine with a 5-axis disc. Different discs are available for obtaining a variety of edge finishes. Operating speed must be tested beforehand.

Installing KERLITE and KERLITE PLUS

In the same manner as all building materials, KERLITE works in combination with other materials. **For this reason, it is essential to:**

- define the characteristics of the support on which slabs will be installed (see "4.1 - Preparing the support")
- choose the right adhesive for the support and intended use (see "4.2 - Recommended adhesives")
- lay KERLITE on the support in the correct manner (see "4.3 - Installation instructions")

If the requirements of these three points are fulfilled, KERLITE will offer all the best of its unique characteristics.

4.1 - Preparing the support

4.1.1 - Supporting material: requirements

Irrespective of whether you are installing on walls or on floors, the support **must** have the characteristics described in detail below. Granting and checking these conditions is at the care of the engineer and of the persons performing installation work.

■ COMPACT

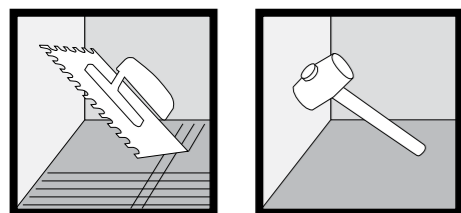

Fig.29/30 - Make sure that the support is compact both in terms of surface and structure. Check compactness of surface by tracing (engraving) a grid on the support with the edge of a trowel or with a steel nail. A support can be considered as compact if it does **not** crumble or pulverise in the point where the lines of the grid intersect. Check compactness of the structure by tapping on the surface with a 750 g mallet: **no** marks should form and the sound heard when tapping must not be hollow. The presence of layers or areas with a more brittle consistence means that mechanical characteristics are poor and may cause breakage or dislodging of slabs.

■ DRY

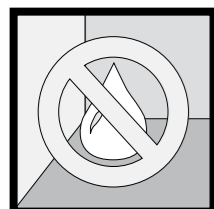

Fig.31 - This test can be performed using a hygrometer for building materials. For cement-based screeds, a moisture content of less than 2% before installation is acceptable. As far as anhydrite screeds are concerned, the moisture content must be lower than 0.5%.

■ FLAT

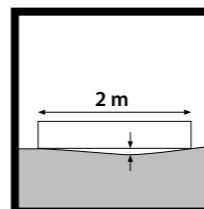

Fig.32 - Flatness checking is performed using a levelling rod with a length of at least 2 metres. Place the rod on the screed in all directions. The permissible tolerance is 2 mm.

■ STABLE OVER TIME

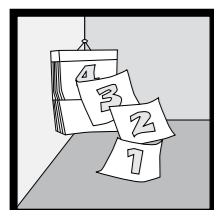

Fig.33 - The support must have suitable features for the intended use and must remain stable over time.

■ CLEAN



Fig.34 - The support must be clean. Dust, oil, grease, dirt and debris must be removed as they may compromise adhesion of the adhesive.

■ NO CRACKS



Fig.35 - In cement-based screeds, the presence of cracks due to hygrometric shrinkage is caused by one or more of the following factors: too much water in the mixture, too fine a grain size of the aggregates, too much cement. Before installation, seal any cracks and holes.

When installing on cement-based floors, the use of self-levelling products, such as Mapei's Ultraplan, guarantees all conditions described above. Use the product in accordance to the manufacturer's instructions.

4.1.2 - Supporting material: instructions for particular situations

For installation on particular supports, apart from the features described in paragraph "4.1.1 - Supporting material: requirements", also take into account the following indications:

INSTALLATION ON EXISTING FLOORS

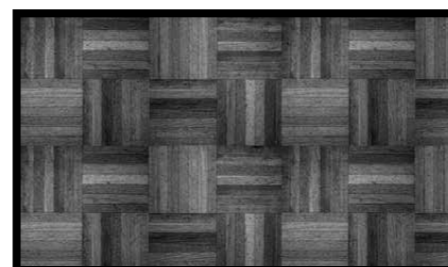

Fig.36 - Wood - Make sure it is sound and firmly secured to the substrate. Remove all residues of oil, paint, grease and wax by sandpapering the surface.

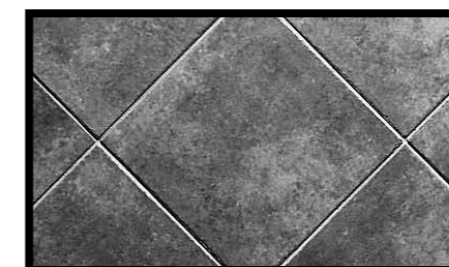
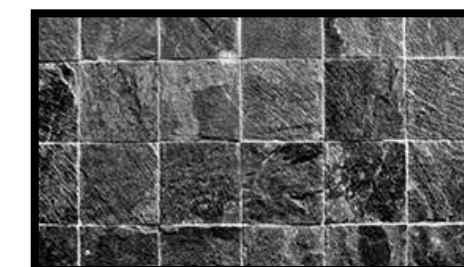

Fig.37/38 - Old ceramic tile, cotto, stone, marble, PVC - Make sure it is sound and firmly secured to the substrate. Eliminate any residues of oil, grease or wax by washing with a solution of water and caustic soda followed by thorough rinsing. If chemical cleaning is not possible, adopt mechanical abrasion techniques.



INSTALLATION ON EXTERIOR PLASTER

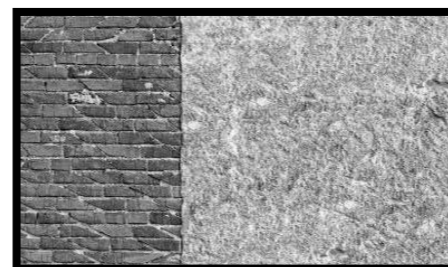

Fig.39 - For wall installation on exterior plaster, KERLITE PLUS must be glued onto a support with a high performance, which resists mechanical stress, such as structural movements, the weight of the tiles, any thermal expansion and atmospheric agents. In this case, we recommend plaster such as KR100 from Fassa Bortolo or BF02 from Grigolin, or plaster with the same characteristics and with an average adhesion capacity to brick of at least 1 N/mm² (approx. 10 kg/cm²). In correspondence with the edges of doors, windows, etc., it is recommended to apply on plaster strips of mesh, such as Mapegrid G 120 from Mapei, positioned at 45°. During installation, pay attention to stringcourses and structural joints.

FLOOR INSTALLATION ON CUSHIONING FOR INSULATION AGAINST SOUND, ETC.

Direct installation on the following products has been checked in the conditions described below. For each of the following systems, follow the manufacturer's instructions and perform work in accordance to "the rules of the trade". After installing the system, make sure that the support on which the slabs will be laid has the features described in paragraph "4.1.1 - Supporting material: requirements".

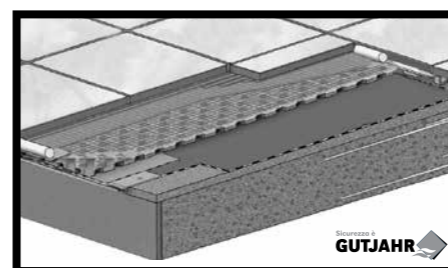

Fig.40 - Watec® Drain Kp from Gutjahr® This is an uncoupling and draining cushioning material. It is used:

- as drainage system for loggias, balconies and bathrooms;
- as uncoupling element in closed environments, such as: critical substrates (existing floors; mixed substrates; etc.); screeds with a high content of calcium sulphate; heated floors; wooden supports and dry screeds.

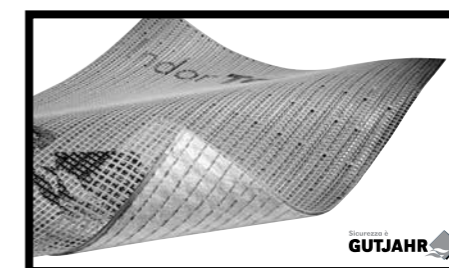

Fig.41 - IndorTec® 2E-PZ from Gutjahr® This is a highly resistant uncoupling system with a reinforced mesh. This product must be glued to the support. It is therefore possible to proceed with tile installation. It can be used in closed environments:

- on critical substrates (existing floors; mixed substrates; etc.);
- fresh, still damp cement screeds;
- heated floors;
- wooden substrates and dry screeds.

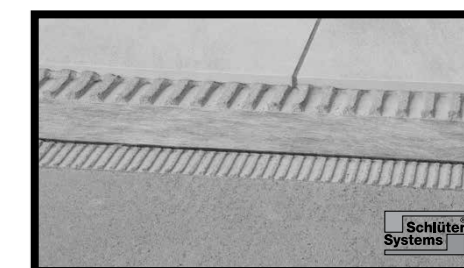

Fig.42 - Ditra sound from Schlüter Systems® This is an insulating mat, made of high density polyethylene, which is suitable for installation with adhesive under ceramic coverings. It has an anchoring fleece laminated on both sides to bond with the tile adhesive.

4.1.3 - Supporting material: instructions for special construction systems

Installation is also possible on **Construction Systems** upon condition that these are installed in accordance to the rules of the trade and the manufacturer's instructions and that the support has the characteristics described in paragraph "4.1.1 - Supporting material: requirements":

INSTALLATION ON FIBRE CEMENT PANEL SYSTEMS (BACKER BOARD)

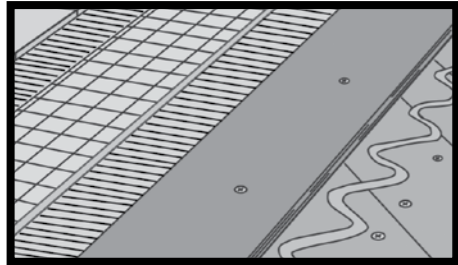

Fig.43 - This system consists of cement-based panels enclosed within two layers of fibre-glass mesh, to be installed both on walls and on floors and secured either mechanically or chemically to the underlying structure. When preparing this support, strictly follow the manufacturer's instructions. Make sure that the points of contact between support and slab are filled with adhesive and that there is an overlying layer of fibreglass mesh submerged in the adhesive used for installation. This will ensure a support without cracks. After installing the system, make sure that the support on which the slabs will be laid has the features described in paragraph "4.1.1 - Supporting material: requirements".

INSTALLATION ON SUSPENDED TIMBER FLOORS

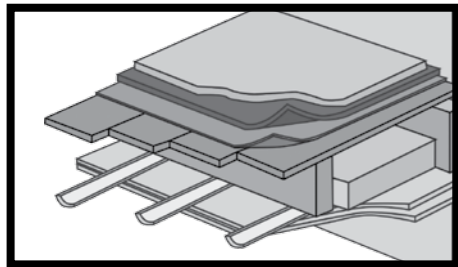

Fig.44 - This construction system consists of a floor made of wooden planks secured by means of nails to a lattice of stringers. Installation of this construction system is similar to that of existing floors, namely "On existing floors - Wood - Fig.36": follow the instructions provided.

INSTALLATION ON SUSPENDED SUPPORTS (E.G. GIFAFLOOR FHBPLUS BY KNAUF)

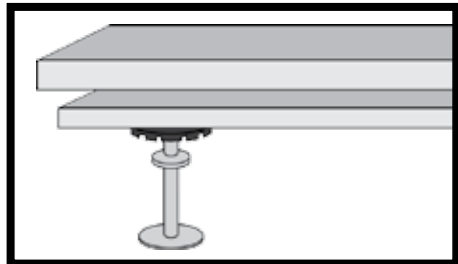

Fig.45 - This system consists of gypsum fibreboard panels resting on steel supports with an adjustable height. When preparing this system, strictly follow the manufacturer's instructions. Make sure that the points of contact between support and slab are filled with adhesive. This will ensure a support without cracks. After installing the system, make sure that the support on which the slabs will be laid has the features described in paragraph "4.1.1 - Supporting material: requirements". Application of a primer before the tile adhesive must be decided upon by the manufacturer of the adhesive you intend to use.

INSTALLATION ON ELECTRICAL HEATING SYSTEMS

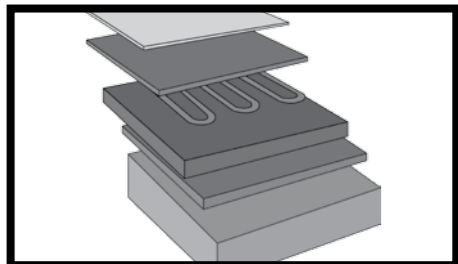

Fig.46 - An evolution of the classical heating system where the radiant element is embedded in the screed. This system consists in installing the radiant element beneath the tiles or rather in the adhesive used for installation of KERLITE or under a layer of self-levelling material. This type of system can be installed directly on a screed or existing floor. A layer of insulating material may be installed in between. Irrespective of the number and type of layers, after the adhesive or self-levelling material has undergone seasoning, you must make sure that the support has the features described in detail in paragraph "4.1.1 - Supporting material: requirements".

WALL INSTALLATION ON UNCOUPLING OR MICROVENTILATED CUSHIONING - SYSTEM CeroVent® BY GUTJAHR®

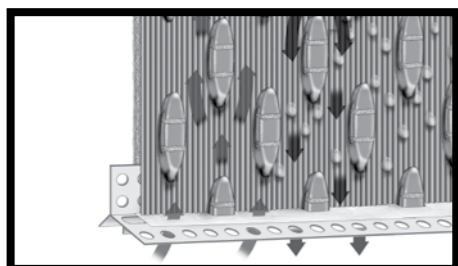

Fig.47 - KERLITE PLUS can be installed directly on the CeroVent® Gutjahr® system. This system allows for wall installation (walls featuring salt and rising damp, damaged facades, mixed supports, prefabricated materials, etc.) and offers microventilation and uncoupling from the substrate.

4.1.4 - Supporting material: instructions for installing in accordance to "the rules of the trade"

Here below you will find some basic information concerning the rules of the trade to follow for the most common types of supporting material:

CEMENT-BASED SCREEDS

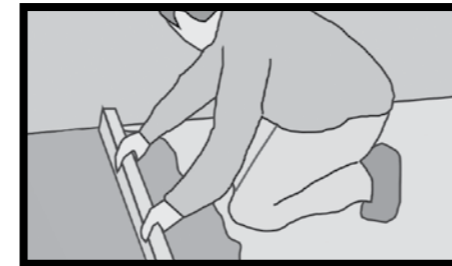

Fig.48 - The curing/seasoning time of cement-based screeds is of essential importance. As far as conventional sand/cement screeds are concerned, this time is about 7/10 days per cm of thickness. If you are using premixed products, such as Mapei's **Topcem Pronto** or Kerakoll's **Keracem Eco Pronto**, follow the instructions of the manufacturer.

General rules for correct construction of a screed:

- aggregates: these must be clean and not contain impure particles. The grain size must be suitable for the thickness of the screed to make;
- levelling strips: these must be made using the same binding agent used for the screed;
- sealing between hardened surfaces and moist mixture: joints between hardened screeds and moist mixture must be made by applying to the end of the hardened screed (clearly cut, perpendicular to the support) adhesion grout, water and binding agent;
- presence of pipelines in the screed: above any pipes, there must be a layer of mortar with a thickness of about 2.5 cm; it is necessary to place, above the pipelines, a metal mesh with a wire thickness of 2 mm so as to provide the necessary reinforcement beneath the thin layer of screed above and prevent the formation of cracks;
- finish: finishing can be performed with a trowel, a steel disc or smoothing tool, paying attention neither to moisten the surface too much nor to work for too long on the same area;
- checking residual moisture: this must be performed after the screed has reached the end of its curing period.

ANHYDRITE SLABS

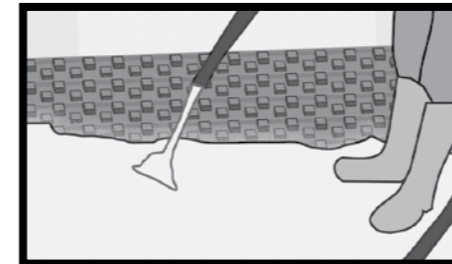

Fig.49 - Follow the instructions of the manufacturer. Before installation, the screed must be sandpapered, dedusted and perfectly dry (the maximum permissible moisture content is 0.5%).

HEATED SCREEDS

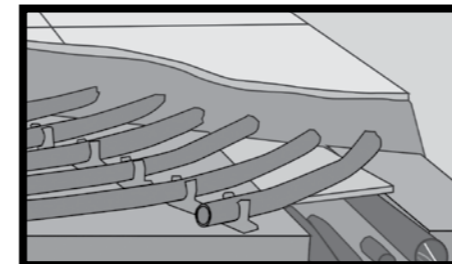

Fig.50 - Before starting the heated floor system, wait at least 14 days after casting the screed. As prescribed by the UNI EN 1264-4 standard, in paragraph 4.4, heating begins at an initial temperature ranging from 20°C to 25°C, which must be maintained for at least 3 days. Then set the maximum permissible design temperature and maintain it for at least 4 days. Once the floor has reached ambient temperature, tile installation can begin.

CONCRETE

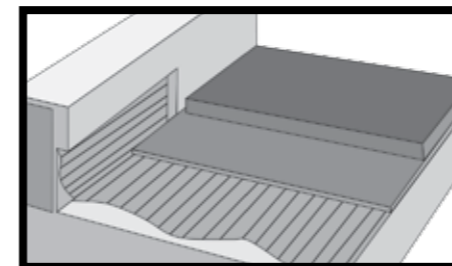

Fig.51 - Concrete must be sufficiently cured (this takes about 6 months or even more, depending on its thickness, composition, thermo-hygrometric requirements, etc.) and must not feature surface treatments such as mould release agents, resin, anti-evaporation treatments, old adhesives, etc. Floor slabs must be insulated against rising damp.

4.2 - Recommended adhesives



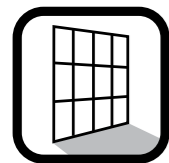

It is essential to follow all instructions given by adhesive manufacturers. This applies in particular to waiting time running before a surface can be walked on or grouted and the "Ready to use" time shown in the following tables.

As a general rule that applies for all building materials to be secured in place with adhesive, there is no universal adhesive for installing KERLITE on all kinds of surface. Since it is not possible to describe all possible cases, we have provided information about the most common situations. First of all, we have divided installation cases into "walls" and "floors" and then into "interior" and "exterior". Depending on the rated stress, on any work to be performed subsequently and on the maximum dimension of the slab, we have assigned a certain type of KERLITE to each category. Starting from this classification, we have thus examined the most common kinds of supporting material. The resulting chart has been sent to all main manufacturers of adhesive that have, in turn, provided the most suitable product for each category. Please note that all solutions suggested have been submitted by adhesive manufacturers, who guarantee the indications given. For explanations or more information, contact the respect manufacturers (see "9 - Handy addresses"). It is essential to follow all instructions given by adhesive manufacturers. This applies in particular to waiting time running before a surface can be walked on or grouted and the "Ready to use" time shown in the following tables.



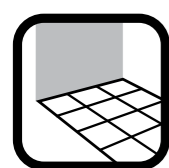

Wall installation

 Interiors	In situations where holes and cuts are NOT necessary and with sizes up to 100 x 100 cm.	KERLITE	Two-coat plaster, gypsum plaster, plasterboard, fibre cement panels	Page 36
	In situations where holes and cuts are necessary.		Concrete, old ceramic tile, marble, stone	Page 37
			Particle board, metal	Page 38
 Exteriors	In situations where holes and cuts are NOT necessary and with sizes up to 100 x 100 cm.	KERLITE PLUS	Two-coat plaster, gypsum plaster, plasterboard, fibre cement panels	Page 39
			Concrete, old ceramic tile, marble, stone	Page 40
	In situations where holes and cuts are necessary and/or for large sizes.		Particle board, metal	Page 41
 Interiors	In situations where holes and cuts are NOT necessary and with sizes up to 100 x 100 cm.	KERLITE	Plaster	Page 42
			Concrete	Page 43
	In situations where holes and cuts are necessary and/or for large sizes.		KERLITE PLUS	Plaster
Concrete		Page 45		



Floor installation

 Interiors	In any situation with the exception of areas subject to heavy loads (e.g. trolleys with hard wheels).	KERLITE PLUS	Cement-based screeds, calcium sulphate-based or heated screeds, self-levelling products, concrete, old ceramic tile, marble slabs, stone	Page 46
			Wood, PVC, rubber, linoleum, metal, resin	Page 47
 Exteriors	Upon condition that surfaces are sheltered (e.g. loggias, covered balconies, etc.) and made totally impervious.	KERLITE PLUS	Cement-based screeds, calcium sulphate-based or heated screeds, self-levelling products, concrete, old ceramic tile, marble slabs, stone	Page 46
			Wood, PVC, rubber, linoleum, metal, resin	Page 47

How to read the attachment

At the discretion of I.S.	Manufacturer	Size of slabs (cm)	Product (*)	Primer, if necessary (*)	Mixing ratio (**)	Class (*)	Nominal coverage (*)	Setting for foot traffic and workability (***)	Ready for use (***)	Installation (*)
01	02	03	04	05	06	07	08	09	10	11

- 01**_ The installation supervisor must examine the conditions of the work site to choose between a normal setting adhesive or a quick setting adhesive.
- 02**_ Adhesive manufacturers.
- 03**_ Depending on the adhesive recommended by the manufacturer, you will find the size in cm of the slab.
- 04**_ List of adhesives recommended by manufacturers based on the intended use and size of the slabs.
- 05**_ List of primers to use before adhesive application, as indicated by manufacturers for each intended use.
- 06**_ The mixing ratio refers to a single product unit (a bag, a can, etc.), in order to obtain the characteristics declared by manufacturers.
- 07**_ The adhesive's class under the UNI EN 12004 standard is indicated. (see "About ADHESIVES" below).
- 08**_ You will find an indication of how many square metres you can install with a single product unit prepared with the established mixing ratio.
- 09**_ You will find the time you must wait before treading on the surface to fill joints with grout.
- 10**_ You will find the time that must pass before using the floor, i.e. before it can go subject to static and/or dynamic stress.
- 11**_ You will find the installation method and features of the trowel to use for each adhesive.

About ADHESIVES

Adhesives are divided into THREE CLASSES , depending on their composition, as established by the UNI EN 12004 standard:
CEMENTITIOUS (C) : mixture of hydraulic binding agents, aggregates and organic additives (note to be mixed with water or other liquid additive immediately before use)
REACTIVE (R) : mixture of synthetic resin, mineral fillers and organic additives, which harden due to a chemical reaction (note: these adhesives may have one or more components)
DISPERSION (D) : mixture of binding and organic agents, namely polymers in aqueous dispersion, organic additives and mineral fillers (note: ready-to-use mixtures)
Depending on their features, adhesives are thus classified:
Class 1 : normal setting
Class 2 : improved setting properties
There are three additional classes:
Class F : quick setting adhesives
Class T : slip resistant adhesives
Class E : adhesives with extended open time
There is a fourth additional class for cementitious adhesives only: adhesives can be classified as DEFORMABLE (S) and divided on the basis of test results under the UNI EN 12002 standard:
Class S1 : deformable adhesives
Class S2 : highly deformable adhesives

4.3 - Instructions for installation

4.3.1 - Adhesives: single-layer method / double-layer method

The installation technique and type of trowel to use depend basically on the type of adhesive used. This information can be found in the "Recommended adhesives" section. Depending on the intended use and on the type of adhesive used, all versions of KERLITE can be installed both with a single-layer of adhesive or with the "double-layer" technique. In all cases, follow the indications below and make sure that support and slab are entirely coated with adhesive.

SINGLE-LAYER METHOD



Fig.52 - Wall installation



Fig.53 - Floor installation

This method refers **only** to adhesives that bear the indication "single-layer" in the "Recommended adhesives" section. Spread the adhesive full-bed on the surface to cover (Fig.52/53), using a trowel with the features indicated in the "Recommended adhesives" section.

DOUBLE-LAYER METHOD



Fig.54

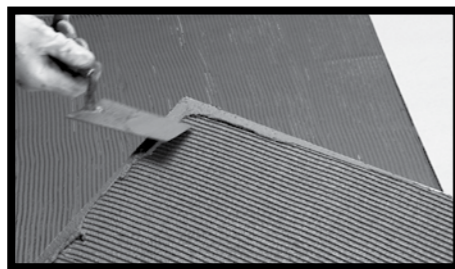

Fig.55

Apply adhesive with the double-layer technique i.e. by spreading the adhesive full-bed on the surface to cover (Fig.52/53), using a notched trowel with tilted teeth at a distance of 6 mm the one from the other (e.g. Raimondi item n°138HFV6). Also apply the adhesive on the under side of the slab, using a trowel with 3 mm teeth (Fig.54). When installing on floors, remember to spread adhesive around the edge of the slab (Fig.55).

BOTH FOR THE SINGLE-LAYER AND DOUBLE-LAYER METHOD



Fig.56



Fig.57

After laying the slab, make sure it is firmly adhering to the underlying surface to prevent gaps and air bubbles forming. For this purpose, you can use rubber coated trowels (e.g. Raimondi "142G") for wall and floor installation (Fig.56) or electrical tile tapping tools with plastic plates (e.g. Raimondi "Cucciolo" Fig.57) for floor installation.

4.3.2 - Laying the slab

Being extremely light, slabs are easy to install.

300x100 slabs:



Fig.58 - 1 -To handle slabs, raise them to their upright position, whilst grasping them from the top edge. Move the slab keeping it straight and with the aid of another person.



Fig.59 - 2 - Rest the slab on its long side and guide it towards the floor.

4.3.3 - Grouting and expansion joints

KERLITE has an expansion coefficient equal to $7.0 \times 10^{-6} \text{ } ^\circ\text{C}^{-1}$ (i.e. for a temperature range of 70°C, expansion is 0.5 mm per linear metre). Despite expansion being minimal, it is however **necessary** to install all types of KERLITE, both for walls and floors, in compliance with the following instructions:



Wall installation

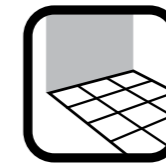

Floor installation

<p>Interiors</p>	<p>Joint between slabs necessary. Minimum size is at least 1 mm.</p>	<p>The size and position of expansion joints must be established by the installation supervisor.</p>	<p>Interiors</p>	<p>Joint between slabs necessary. Minimum size is at least 2 mm.</p>	<p>Expansion joints are necessary. The size and position of joints must be established by the installation supervisor. As a general rule, provide at least every 15/20 m²</p>
<p>Exteriors</p>	<p>Joint between slabs necessary. Minimum size is at least 5 mm.</p>	<p>Expansion joints are necessary. The size and position of joints must be established by the installation supervisor. As a general rule, provide at least every 9 m².</p>	<p>Exteriors</p>	<p>Joint between slabs necessary. Minimum size is at least 5 mm.</p>	<p>Expansion joints are necessary. The size and position of joints must be established by the installation supervisor. As a general rule, provide joints every 9 m².</p>

Upon condition that surfaces are sheltered (e.g. loggias, covered balconies, etc.) and made totally impervious.

FURTHERMORE:

		<p>Interiors Wall installation Floor installation</p>			<p>Exteriors Wall installation Floor installation</p>
--	--	--	--	--	--

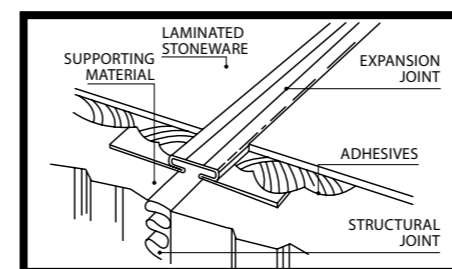

Fig.60 - In correspondence with a structural joint in the screed, it is **mandatory** to provide an expansion joint with a width that is at least the size of the existing one.

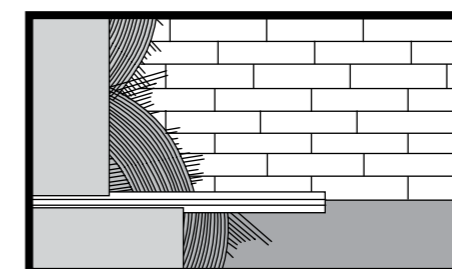

Fig.61 - If there are joints between surfaces of different types (e.g. reinforced concrete and bricks), it is **mandatory** to provide an expansion joint.

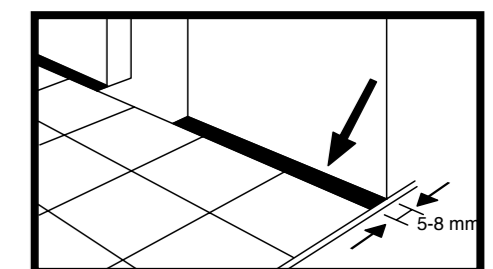

Fig.62 - Around fixed elements of the supporting surface, such as walls, steps, columns, etc., it is **mandatory** to provide 5-8 mm peripheral joints.

For suggestions on the type of joint to use, see "Connecting profiles, finishing and trim pieces". Please also remember that expansion joints can be made using silicone products.

Cleaning and care

■ CLEANING AFTER INSTALLATION

Cleaning "after installation" is necessary for removing residues of grout, cement and mortar. This operation is mandatory after installation both for glazed tiles and unglazed ones.

Non-slip surfaces: due to their particular, non-slip, rough or structured textures, these surfaces are more difficult to clean. Therefore pay particular attention to cleaning, in particular clean sooner and use motorised brushes with white and beige discs.

Grout used	When to clean	What to use	Methods of use
Cementitious grout mixed with water.	After 4/5 days and within 7 days from grouting.	Acid-based detergent (see "List of acid-based detergents")	Follow the instructions of the detergent manufacturer. As a general rule, before treatment, surfaces to clean must be thoroughly moistened with water. Then apply the detergent and, if necessary, scrape of any residues with a putty knife or abrasive sponge. If residues are particularly hard to remove, repeat. Soak up liquid and rinse thoroughly and repeatedly with water. Brush and dry with a cloth.
Epoxy grout, Cementitious grout with additives (resin, latex, etc.).	Immediately	Follow the instructions of the grout manufacturer.	Any grout residues must be removed before they harden. Before grouting, perform a cleaning test to find out when grout hardens and when it should be cleaned.



If after-installation cleaning has not been correctly performed

List of acid-based detergents	
Follow the instructions given on the package. Test the product on a tile before actual use. This applies in particular to lapped or polished products.	
Name of detergent	Manufacturer
Keranet	Mapei
Deltaplus	Kerakoll
Cement Remover	Faberchimica
Pavim	PanariaGroup
Deterdek	Fila
Trek	Kiter
Zementschleierentferner	Lithofin
HMK R63	HMK
Solvacid	Geal
Litoclean Plus	Litokol
Bonaclean	Bonasystems Italia
Bonadecon (*)	Bonasystems Italia
(*) especially made for materials that are not acid-resistant.	

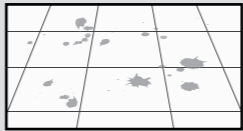
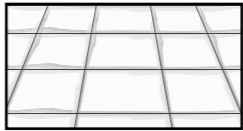
Grout used	What do you see	What should you do
Cementitious grout mixed with water.	Residues, glossy films. 	Use the same acid-based detergent used for after-installation cleaning but dilute less. Apply the detergent and scrape residues with a putty knife or abrasive sponge. If residues are particularly hard to remove, repeat. Soak up liquid and rinse thoroughly and repeatedly with water. Brush and dry with a cloth.
Epoxy grout, Cementitious grout with additives (resin, latex, etc.).	Marks, in particular around the grouting joints. 	Once it has hardened, grout is very difficult or even impossible to remove. Contact the grout manufacturer.

■ PROTECTIVE AGENTS FOR GROUTING JOINTS

These are used to reduce porosity and therefore make cementitious grout more resistant to stains. Use of protective agents can make cleaning easier. Follow the instructions given on the package. Test the product on a tile before actual use. This applies in particular to lapped or polished products.

Grout used	Product name	Manufacturer	Methods of use
Cementitious grout mixed with water	Fugaproof KF Fugenschutz	Fila Lithofin	Follow the manufacturer's instructions.

■ NON-SLIP TREATMENT

Non-slip properties of installed floors (glazed or unglazed) can be improved using specific products. Follow the instructions given on the package. Before application on an installed floor, test the product on a loose tile. The longer you leave the product on the tile, the more you increase non-slip properties. However, this can whiten the tiles a little and make cleaning a little more difficult.

Product name	Manufacturer	Methods of use	Maintenance
Safe Floor Safe Floor 30 Bonagrip	Faberchimica Faberchimica Bonasystems Italia	Follow the manufacturer's instructions.	Follow the manufacturer's instructions.

■ DAILY CLEANING

For daily care, use neutral detergents diluted in plenty of warm water. Detergents should not contain wax or leave glossy stains. Dry with a microfibre cloth. Rinse with water after washing and dry with a clean microfibre cloth.

Support to clean	What to use	Methods of use
KERLITE KERLITE PLUS DECORATIONS	Neutral detergent without wax (see "List of detergents"). NEVER use alcohol, acid, solvents, abrasive detergents, abrasive sponges or pads.	Diluted in plenty of warm water. Rinse thoroughly after washing. For all operations (washing, rinsing and drying), use good quality microfibre cloths.

List of detergents

Follow the instructions given on the package. Test the product before actual use on a tile. This applies in particular to lapped or polished products.

Name of detergent	Manufacturer
Floor Cleaner	Faberchimica
Fila Cleaner	Fila
Pflegereiniger	Lithofin
HMK P15	HMK
Bonamain Plus (*)	Bonasystems Italia
Bonadecon (*)	Bonasystems Italia
(*) DO NOT use for cleaning DECORATIONS	

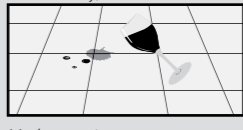
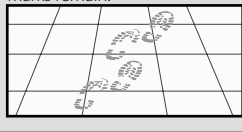

If daily cleaning has been done using unsuitable detergents

Support to clean	What do you see	What should you do
KERLITE KERLITE PLUS DECORATIONS	Glossy marks that are visible against light. 	Apply a mildly acid detergent (e.g. Tile Cleaner from Faberchimica or Bonamain PLUS from Bonasystems Italia). Use product undiluted and let it work for 5 to 10 minutes. Then rub with a white pad, rinse with plenty of water and dry with a microfibre cloth.
	Stains easily, absorbs. 	
	Marks remain. 	

■ EXTRA-DUTY CLEANING

Support to clean	Type of dirt	What to use	Methods of use	Name of detergent	Manufacturer	
KERLITE KERLITE PLUS	Coffee, Coca Cola®, fruit juice	Alkaline-based detergent	Follow the instructions of the detergent manufacturer.	Coloured stain remover PS87 Greslind	Faberchimica Fila PanariaGroup	
	Grease, dust from foot traffic, deep-down cleaning	Alkaline-based detergent	Follow the instructions of the detergent manufacturer.	PS87 Litonet Greslind Intensivreiniger HMK R55 Taski R20-strip Bonamain, Bonadecon	Fila Litokol PanariaGroup Lithofin HMK Johnsondiversey Bonasystems Italia	
	Wine	Oxidising detergent	Follow the instructions of the detergent manufacturer.	Oxidant	Faberchimica	
	Lime residues	Acid-based detergents	Follow the instructions of the detergent manufacturer. Test the product on a tile before actual use. This applies in particular to lapped or polished products.	Viakal	Procter & Gamble	
	Rust	Acid-based detergents	Dilute the product and apply on the stain. Allow to work for 10/20 minutes then rinse thoroughly. If necessary repeat. Test the product on a tile before actual use. This applies in particular to lapped or polished products.	Diluted muriatic acid	(various makers)	
	Tyre marks, pencil marks and metal marks	Abrasive paste	Follow the instructions of the detergent manufacturer. Test the product on a tile before actual use. This applies in particular to lapped or polished products.	Polishing cream Vim clorex Detergum (*) Strong remover (*) (*) DO NOT use on lapped or polished products.	Faberchimica Guaber Zep Italia Faberchimica	
	Ink, marker	Solvent-based detergent	Solvents should be applied undiluted on the stain. Let them work for about 15/30 seconds. If necessary repeat. As far as "Coloured stain remover" is concerned, follow the manufacturer's instructions.	Nitro thinner 1,2-dichloroethylene Turpentine Coloured stain remover	(various makers) (various makers) (various makers) Faberchimica	
	Dirt from grout	Detergent for grout	Follow the instructions of the detergent manufacturer.	Fuganet Fugenreiniger	Fila Lithofin	
	DECORATIONS	Any	Neutral, wax-free detergent	Use water and a neutral, wax-free detergent. NEVER use alcohol, acid, solvents, abrasive detergents, abrasive sponges or pads.	Floor Cleaner Fila Cleaner Pflegereiniger HMK P15 Bonamain Plus	Faberchimica Fila Lithofin HMK Bonasystems Italia

Connecting profiles, finishing and trim pieces



You can complete all versions of KERLITE walls and floors with the profiles available on the market.

Here below you will find some possible solutions using the profiles sold by the main manufacturers of the sector. The solutions described have different characteristics and sizes, depending on the manufacturer, and cannot be described in detail herein. The drawings and instructions for use are therefore indicative and of a general nature. For more information and to gain an exhaustive idea of the complete ranges offered, refer to the manufacturer. You will find a list of references in "9 - Handy addresses".

PROFILITEC S.p.A.	www.profilitec.com	PROGRESS PROFILES	www.progressplast.com
SCHLÜTER-SYSTEMS ITALIA SRL	www.schlueter.it	PROFILPAS	www.profilpas.com
WEDI	www.wedi.it	DURAL	www.dural.de/en
RARE	www.rareboxdoccia.com		

PROFILES FOR DOORS AND WORK TOPS	Manufacturer	Best-selling products
Full profile		
	Profilitec	Planotec BP
	Progress Profiles	Protop
Profiles with tile compartment		
	Progress Profiles	Protect J, T, Q

WALL/FLOOR AND INNER CORNER	Manufacturer	Best-selling products
Bullnose		
	Profilitec	BA Bullnose
	Progress Profiles	Bullnose 40
	Profilpas	Metal Line
	Dural	Construct
Bullnose profile		
	Profilitec	BT bullnose
	Progress Profiles	Printer KL ALL
Minimum quarter round cove		
	Profilitec	Mosaitec CRM
	Progress Profiles	Proshell D ALL
	Profilpas	Proround/Proint
Quarter round cove		
	Profilitec	Coflex CR
	Progress Profiles	Proshell R ALL
	Profilpas	Proround/Proint
Obtuse angle profiles		
	Profilitec	Sanitec SB
	Schlüter®-Systems	ECK-KHK
	Progress Profiles	Proseal
	Profilpas	Saniboard
	Dural	Duracove
Right angle profiles		
	Schlüter®-Systems	ECK-KI
	Progress Profiles	Probat
	Profilpas	Saniboard

SHOWER SYSTEMS	Manufacturer	Best-selling products
Stainless steel grill		
	Profilitec	Grill drain
	Schlüter®-Systems	Kerdi-Line-H
	Dural	BASIC-LINE
	Wedi	Riolito esclusiv, Level 3
Grill with tile compartment		
	Profilitec	Tile grill drain
	Schlüter®-Systems	Kerdi-Line-D
	Dural	TI-LINE
	Wedi	Riolito shower base
Shower base system		
	Schlüter®-Systems	Kerdi-Shower
	Dural	TILUX
	Wedi	Fundo Primo / Plano
	Rare	Ad Hoc

EXPANSION JOINTS	Manufacturer	Best-selling products
Floor joints		
	Profilitec	Coflex CA
	Schlüter®-Systems	Dilex-BWS
	Progress Profiles	Proflex
	Profilpas	NTA/NTI
	Dural	Duraflex
Perimeter joints		
	Profilitec	Coflex CAJP
	Schlüter®-Systems	Dilex-BWA
	Progress Profiles	Proflex 5 PR
	Profilpas	NJ
	Dural	Duraflex SF

SURMOUNTED ELEMENTS AND COVERING PROFILES	Manufacturer	Best-selling products
Connection		
	Profilitec	Ramptec ZRR
	Schlüter®-Systems	Reno-U
	Progress Profiles	Proslider KL ALL
	Profilpas	Pronivel
Surmounted element		
	Profilitec	Variotec DK
	Schlüter®-Systems	Reno-T
	Progress Profiles	Profloor 24
	Profilpas	Prolevel
	Dural	LPTE
Straight edge covering profile		
	Profilitec	Squarejolly SJ
	Schlüter®-Systems	Quadec
	Progress Profiles	Projolly Square
	Profilpas	Proangle Q
	Dural	Squareline
Rounded edge covering profile		
	Profilitec	Roundjolly RJ
	Schlüter®-Systems	Rondec
	Progress Profiles	Projolly Quart
	Profilpas	Protrim

CURVED PROFILES	Manufacturer	Best-selling products
Metal profile for curves		
	Profilitec	Trimtec TR
	Schlüter®-Systems	Schiene
	Progress Profiles	Proterminal
	Profilpas	Proflex Line
	Dural	Z-FLEX

STEPS AND OUTER CORNERS	Manufacturer	Best-selling products
Profiles for protruding steps		
	Profilitec	Stairtec FL
	Schlüter®-Systems	Rondec
	Progress profiles	Prostyle KL10
	Profilpas	Prostep
Reinforced profiles for steps		
	Schlüter®-Systems	TREP-E
	Profilpas	Prostep SMA
	Dural	Diamondstep
Rounded profiles with non-slip tread		
	Profilitec	Stairtec FO
	Schlüter®-Systems	TREP-GK
	Progress Profiles	Prostair KL 20
	Profilpas	Prostep
Rounded profile		
	Profilitec	Roundjolly RJ
	Schlüter®-Systems	Rondec
	Progress Profiles	Projolly Quart
	Profilpas	Protrim
Straight edge profile		
	Profilitec	Squarejolly SJ
	Schlüter®-Systems	Quadec
	Progress Profiles	Projolly Square
	Profilpas	Proangle Q
	Dural	Squareline
Thin corner profile		
	Profilitec	Mosaitec RJF
	Progress Profiles	Prokerlam LINE
	Profilpas	Probord IPA
Corner profiles		
	Profilitec	Stairtec SE
	Schlüter®-Systems	ECK-K
	Progress Profiles	Proedge
	Profilpas	Procorner
	Dural	Duragard

Making corners during installation

7.1 - Solution 1



You can obtain "handmade" corner finishes with an attractive appearance and without using corner profiles.

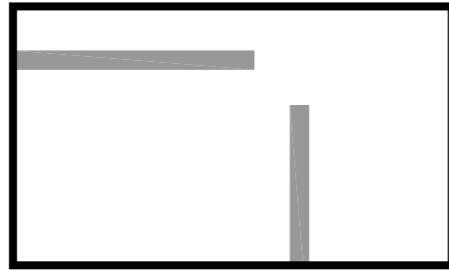

1 - KERLITE or KERLITE PLUS slabs.

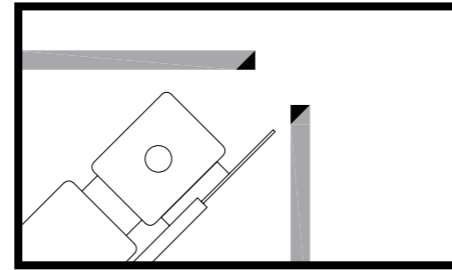

2 - Provide a 45° cut on the inner edge of the slab with an angle grinder or cutter.



3 - Spread adhesive on the support.

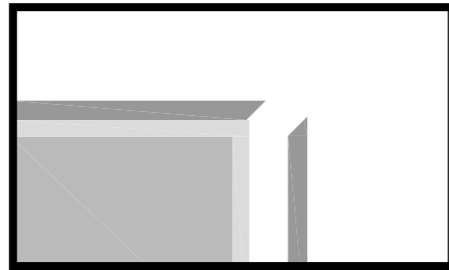

4 - Lay the first slab.

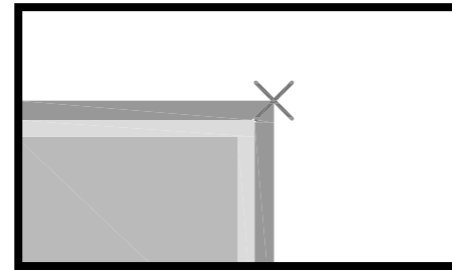

5 - Lay the second slab using 1 mm spacer crosses.

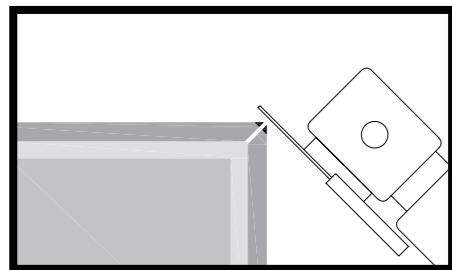

6 - Let the adhesive cure. Provide a 45° cut on the edge with a cutter.

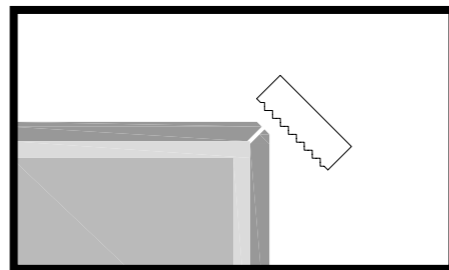

7 - Smoothen the edge with an abrasive sponge.

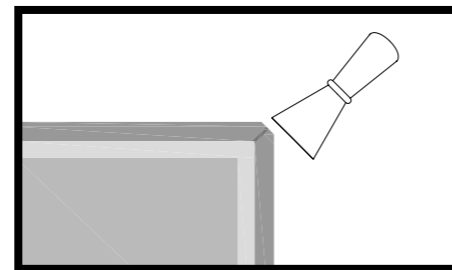

8 - Apply epoxy grout with a trowel (*).

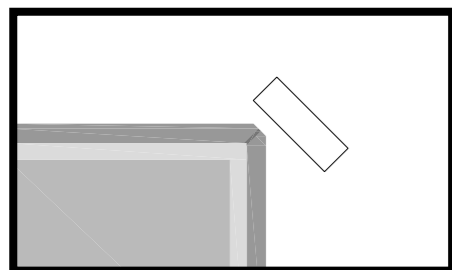

9 - Remove excess grout with a sponge moistened in warm water and alcohol (*).

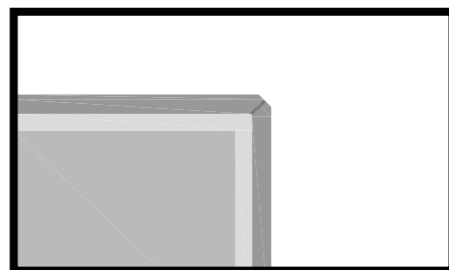

10 - The corner is now ready.

7.2 - Solution 2

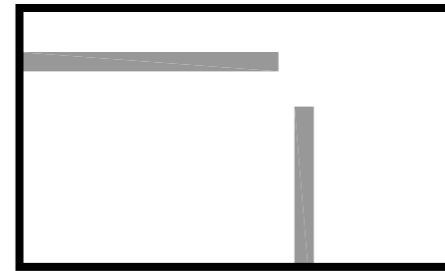

1 - KERLITE or KERLITE PLUS slabs.

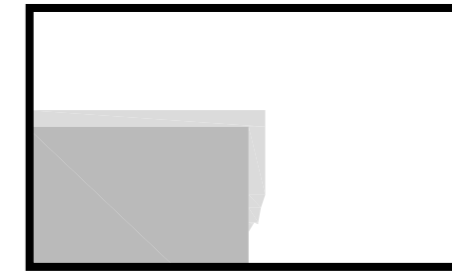

2 - Spread adhesive on the support.

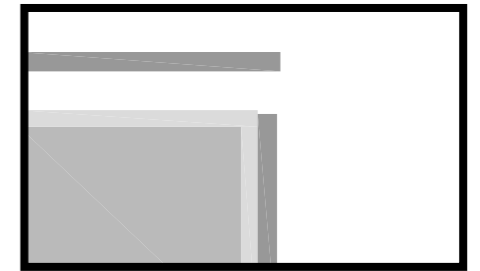

3 - Lay the first slab.

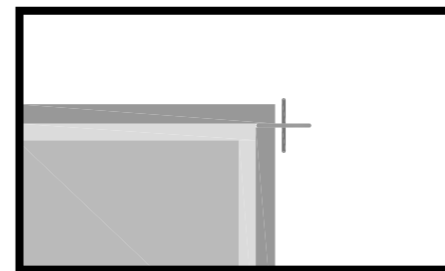

4 - Lay the second slab using 1 mm spacer crosses

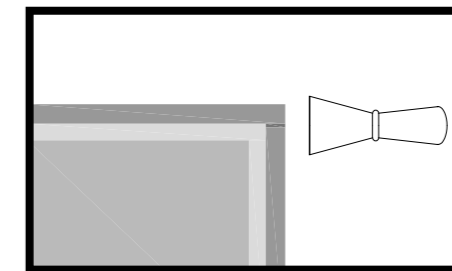

5 - After adhesive has cured, apply epoxy grout with a trowel (*).

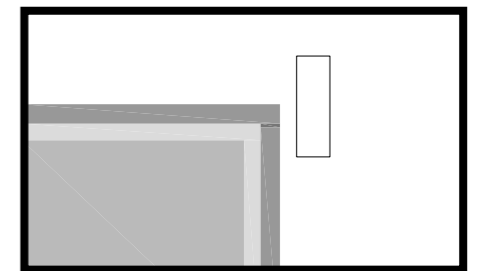

6 - Remove excess grout with a sponge moistened in warm water and alcohol (*).

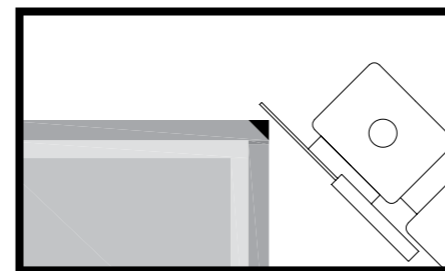

7 - After grout has cured, provide a 45° cut with an angle grinder (*).

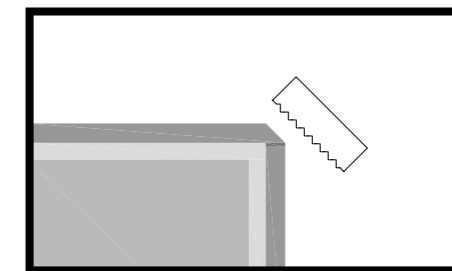

8 - Smoothen the edge with an abrasive sponge.

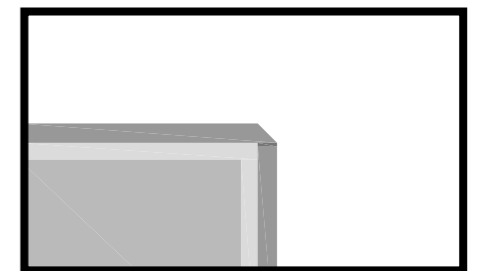











9 - The corner is now ready.



(*). To perform this operation, strictly follow the instructions provided by the epoxy grout manufacturer.



Technical information

8.1 - Technical characteristics

TECHNICAL CHARACTERISTICS					
	Technical characteristic	Test method	Required value EN 14411 - G / ISO 13006 - G Group, Bla-UGL	KERLITE values	KERLITE PLUS values
	Water absorption (E)	ISO 10545-3	≤ 0.5%	≤ 0.1%	≤ 0.1%*
	Bending strength	ISO 10545-4	≥ 35 N/mm ²	≥ 35 N/mm ²	≥ 120 N/mm ² **
	Breaking strength	ISO 10545-4	≥ 700 N	Not required Wall tiles	≥ 1000 N**
	Deep abrasion resistance	ISO 10545-6	≤ 175 mm ³	Compliant	Compliant
	Compression strength	-	Iso makes no provision for this test	Not required Wall tiles	≥ 400 N/mm ²
	Linear thermal expansion	ISO 10545-8	Iso makes no provision for this test	$\alpha \leq 7 \cdot 10^{-6} \text{ } ^\circ\text{C}^{-1}$	$\alpha \leq 7 \cdot 10^{-6} \text{ } ^\circ\text{C}^{-1}$
	Thermal shock resistance	ISO 10545-9	Iso makes no provision for this test	Resistant	Resistant
	Frost resistance	ISO 10545-12	No alteration	Resistant	Resistant
	Chemical resistance	ISO 10545-13	As indicated by manufacturer	ULA - UHA (resistant)	ULA - UHA (resistant)
	Household chemicals resistance	ISO 10545-13	UB min	UA (resistant)	UA (resistant)
	Stain resistance	ISO 10545-14	Class 3 min.	5 (resistant)	5 (resistant)
	Dimensions	Length and width	ISO 10545-2	± 0.6%	± 0.6%
		Straightness of sides		± 0.5%	± 0.2%
		Rectangularity		± 0.6%	± 0.2%
		Flatness		± 0.5%	± 0.5%
		Thickness		± 5%	± 5%



* Value refers to ceramic material

** Value refers to complete piece (slab and reinforcement)

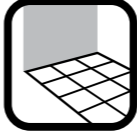
SLIP RESISTANCE					
	Safety requirements	Test method	Reference requirement	KERLITE values	KERLITE PLUS values
	Dynamic friction coefficient	B.C.R.	>0,40 L. 13/89 - D.M. 236/89 D. Lgs. 503/96	Not required Wall tiles	>0,40 leather-dry / rubber-wet (excluding Over)
	Slip resistance	DIN 51130	R9 $6^\circ \leq \alpha \leq 10^\circ$ R11 $19^\circ \leq \alpha \leq 27^\circ$	Not required Wall tiles	R9 (excluding Over) R11 (Geoquartz) Class B (A+B) (Geoquartz)
		DIN 51097	Class B (A+B) ($18 \leq \alpha < 24^\circ$)		

FIRE REACTION					
	Safety requirements	Test method	Reference requirement	KERLITE values	KERLITE PLUS values
WALL INSTALLATION					
	Fire reaction	ISO DIS 1182.2	Italian standard M.D. 14/01/85 M.D. 15/03/05	Class 0	Class 1
	Fire reaction	UNI EN 13823:2005	European standard Directive 89/106/CE Decision 2000/147/CE UNI EN 13501-1:2005	Class A1	Class A2 - s1,d0
FLOOR INSTALLATION					
	Fire reaction	ISO DIS 1182.2	Italian standard M.D. 14/01/85 M.D. 15/03/05	Class 0	Class 1
	Fire reaction	UNI EN 13823:2005	European standard Directive 89/106/CE Decision 2000/147/CE UNI EN 13501-1:2005	Class A1 _{f1}	Class A2 _{f1} - s1

THERMAL CHARACTERISTICS				
	Safety requirements	Test method	KERLITE values	KERLITE PLUS values
	Thermal conductivity	UNI EN 12524:2001	$\lambda = 1.3 \text{ W/m}^\circ\text{K}$ $\lambda = 1.1 \text{ kcal/m } ^\circ\text{C}$	$\lambda = 1.3 \text{ W/m}^\circ\text{K}$ $\lambda = 1.1 \text{ kcal/m } ^\circ\text{C}$



PHYSICAL-MECHANICAL CHARACTERISTICS				
	Safety requirements	Test method	KERLITE values	KERLITE PLUS values
	Elastic modulus (Young's Modulus)	-	55 - 60 GPa	55 - 60 GPa
	Density	-	2300 - 2500 kg/m ³	2300 - 2500 kg/m ³
	Sound absorption coefficient α	UNI EN ISO 11654	0.01 - 0.02	0.01 - 0.02

8.1 - Technical characteristics

TECHNICAL CHARACTERISTICS						
	Technical characteristic	Test method	ANSI 137.1 Required value for unglazed porcelain tiles P1 Class	KERLITE values	KERLITE PLUS values	
	Water absorption (E)	ASTM C373	≤ 0.5% (Fully vitrified)	Compliant	Compliant (*)	
	Breaking strength (S)	ASTM C648	≥ 250 lbf	Not required: Wall Tiles	Compliant (**)	
	Deep abrasion resistance	ASTM C1243	≤ 175 mm ³	Compliant	Compliant	
	Compression strength	-	Ansi makes no provision for this test	≥ 56000 PSI	≥ 56000 PSI	
	Linear thermal expansion	ASTM C372	Not required	$\alpha \leq 8 \times 10^{-6} \text{ } ^\circ\text{C}^{-1}$ $\alpha \leq 4.4 \times 10^{-6} \text{ } ^\circ\text{F}^{-1}$	$\alpha \leq 8 \times 10^{-6} \text{ } ^\circ\text{C}^{-1}$ $\alpha \leq 4.4 \times 10^{-6} \text{ } ^\circ\text{F}^{-1}$	
	Thermal shock resistance	ASTM C484	Not alteration	Resistant	Resistant	
	Frost-resistance	ASTM C1026	Not required	Resistant	Resistant	
	Chemical resistance	ASTM C650	Not required	Resistant	Resistant	
	Bond strength		≥ 50 PSI	Compliant	Compliant	
	Stain resistance	ASTM C1378	Not required	Resistant	Resistant	
	Dimensions	Warpage edge	ASTM C485	± 0.40% or max ± 0.05 inch for tiles up to 24"x24" or max ± 0.07 inch for tiles larger to 24"x24"	Compliant	Compliant
		Warpage diagonal	ASTM C485	± 0.40% or max ± 0.07 inch	Compliant	Compliant
		Nominal sizes	ASTM C499	- 3.0% / + 2.0% of nominal dimensions	± 0.5%	± 0.5%
		Caliber range	ASTM C499	± 0.25% or max ± 0.03 inch	Compliant	Compliant
		Thickness	ASTM C499	≤ 0.040 inch	≤ 0.030 inch	≤ 0.030 inch
		Wedging	ASTM C502	± 0.25% or max ± 0.03 inch	Compliant	Compliant

* Value referred to ceramic material only.

** Value referred to the all-in-one piece (slab and fiberglass mesh).

SLIP RESISTANCE					
	Safety requirements	Test method	Reference requirement	KERLITE values	KERLITE PLUS values
	Static coefficient of friction (SCOF)	ASTM C 1028	SCOF < 0.50 questionable 0.50 ≤ SCOF < 0.60 conditionally slip resistant SCOF ≥ 0.60 slip resistant	Not required Wall tiles	Refer to specific collection catalogue
	Dynamic coefficient of friction (DCOF)	ANSI 137.1: PAR. 6.2.2.1.10 (BOT 3000)	DCOF > 0.42 (wet internal spaces)	Not required Wall tiles	Refer to specific collection catalogue

THERMAL CHARACTERISTICS				
	Safety requirements	Test method	KERLITE values	KERLITE PLUS values
	Thermal conductivity	UNI EN 12524:2001	λ = 0.7 Btu/ft h°F	λ = 0.7 Btu/ft h°F

8.2 - Texts for tenders

Title	Description
Thickness	KERLITE 3MM: 3 mm. KERLITE PLUS: 3,5 mm.
Sizes	KERLITE 3MM: cm. 100x300 - 100x100 - 40x100 - 4,9x100 - 33,3x100 - 50x50 - Trilogy 40x100 - Stripes 40x100 KERLITE PLUS: cm. 100x300 - 100x100 - 50x100 - 33,3x100 - 50x50 - 20x150 - 14,3x100 - 33,3x33,3
Series and colours	COLORS: LAKE, SAND, SNOW, STEEL, SMOKE, NIGHT ELEGANCE: VIA TORNABUONI, VIA CONDOTTI, VIA MONTENAPOLEONE, VIA FARINI BUXY: CORAIL BLANC, AMANDE, CAMEL, CENDRE, NOISETTE, PERLE, CARBON BLUESTONE AVANTGARDE: BLUESTONE, PIETRA D'IRLANDA, PIETRA CHIARA OVER: LOFT, OFFICE, OPENSACE, ROAD OAKS: POLAR, FOSSIL, LAND, RAIN, TIMBER BLACK-WHITE: BLACK, WHITE, ULTRAWHITE GEOQUARTZ: DOVER, SINAI, ETNA STYLING: SPACE, MOOD, GLAM, VOGUE, STAR, RIVER, DESERT, CORAL EXEDRA: CALACATTA, ESTREMOZ, MARFIL, TRAVERTINO, PULPIS, AMADEUS
Type of surface	Unglazed (UGL)
Shaping method	Pressing
Water absorption in accordance to EN ISO 10545.3	≤ 0,5%
Classification in accordance to EN 14411/ISO 13006	Group Bla
Reference specifications for first grade product in accordance to EN 14411/ISO 13006	EN 14411/ISO 13006 Appendix G
Performance classification in accordance to	EN - ISO - DIN - BCRA
Declared safety features	Slip resistance • Method BCRA: > 0,40 (leather-dry / rubber-wet) (excluding the Over serie) • Method DIN 51130: R9 (excluding the Over serie) / R11 (serie Geoquartz) • Method DIN 51097: class C (A+B+C) (serie Geoquartz) Release of toxic/harmful substances ISO 10545.15 - none Fire reaction, Italy (DM 14/01/85, DM 15/03/05, method ISO/DIS 1182.2) • KERLITE 3MM: class 0 • KERLITE PLUS: class 1 Fire reaction, European Union (Dir. 89/106/CE, Dec. 2000/147CE, UNI EN 13501-1:2005, method UNI EN 13823:2005) KERLITE 3MM: class A1 (walls), class A1 _f (floors) KERLITE PLUS: class A2-s1,D0 (walls), class A2 _f -s1 (floors)
Data for the technical chart	New ceramic mineral produced in 300x100 cm slabs of porcelain stoneware, obtained using raw materials of high quality and purity (light clay, feldspar fluxes and ceramic pigments with a high chromatic performance). After wet milling, the mixture is coloured and spray dried, then pressed by compacting on a belt with a force of 15,000 tons and fired at a temperature of 1200°C.

8.3 - Packages

Slizes (cm.)	pieces/boxes	sq.mt./boxes	kg/boxes	boxes/pallet	sq.mt./pallet	kg/pallet
100x300x0,35 KERLITE PLUS	-	-	-	12 pz.	36	280,8
100x300x0,3 KERLITE 3 MM	-	-	-	13 pz.	39	288,6
100x100x0,35 KERLITE PLUS	3	3	23,4	25 pz.	75	585
100x100x0,3 KERLITE 3 MM	3	3	22,2	25 pz.	75	555
20x150x0,35 KERLITE PLUS	5	1,5	12,8	40	60	512
50x100x0,35 KERLITE PLUS	5	2,5	20	32	80	640
40x100x0,3 KERLITE 3 MM	5	2	14,2	35	70	497
40x100x0,3 Trilogy KERLITE 3 MM	4	1,6	11,2	15	24	168
40x100x0,3 Stripes KERLITE 3 MM	1	0,4	2,8	80	32	224
33,3x100x0,3 KERLITE 3 MM	5	1,665	12,5	35	58,275	425,25
33,3x100x0,35 KERLITE PLUS	5	1,665	12,98	35	58,275	425,30
50x50x0,35 KERLITE PLUS	7	1,75	13,65	48	84	655,2
50x50x0,3 KERLITE 3 MM	8	2	14,8	48	96	710,4
14,3x100x0,35 KERLITE PLUS	10	1,43	12	40	57,2	480
4,9x100x0,3 KERLITE 3 MM	10	0,490	3,9	39	19,11	152,1
33,3x33,3x0,35 KERLITE PLUS	7	0,776	6,22	96	74,51	597,17

Handy addresses

The companies mentioned in this manual are our own choices and are therefore recommended but not an obligatory choice.

Adhesives

MAPEI S.p.A.

Via Cafiero 22
20158 (MI) - Italia
Tel. +39 02 37673
www.mapei.it

KERAKOLL S.p.A

Via dell'Artigianato, 9
41049 Sassuolo (MO) - Italia
Tel. +39 0536 811516
www.kerakoll.com

LATICRETE S.r.l.

Piazza Martiri, 7
19020 Brugnato (SP) - Italia
Tel. +39 0187 897470
Fax +39 0187 896881
e-mail info@laticrete.it
www.laticrete.it

LITOKOL S.p.A

Via G. Falcone, 13/1
42048 Rubiera (RE) - Italia
Tel. +39 0522 622811
Fax. +39 0522 620150
e-mail info@litokol.it
www.litokol.it

SAINT-GOBAIN / WEBER S.p.A

Via Sacco e Vanzetti, 54
41042 Fiorano Modenese (MO) - Italia
Tel. +39 0536 837111
e-mail info@netweber.it
www.netweber.it

PCI - BASF Construction Chemicals Italia S.p.A

Via Vicinale delle corti, 21
31100 Treviso (TV) - Italia
Tel. +39 0422 304251
e-mail vittorio.rossi@basf.com
www.basf-cc.it

ARDEX S.r.l

Via Alessandro Volta, 73 (Località Pigna)
25015 Desenzano del Garda - Italia
Tel. +39 0309 119952
www.ardex.it

Profiles and trim pieces

PROFILITEC S.p.A.

Via Brescia, 43
36040 Torri di Quartesolo (VI) - Italia
Tel. +39 0444 268311
Fax +39 0444 268310
www.profilitec.com

SCHLÜTER-SYSTEMS Italia S.r.l.

Via Bucciardi 31/33
41042 Fiorano Modenese (MO)
Tel. +39 0536 914511
Fax +39 0536 911156
www.schlueter.it

PROGRESS PROFILES S.p.A.

Via dell'Artigianato, 35/37
31011 Asolo (TV) - Italia
Tel. +39 0423 950398
Fax +39 0423 950979
www.progressprofiles.com

PROFILPAS S.p.A.

Via Einstein, 38
35010 Cadoneghe (PD) - Italia
Tel. +39 049 8878411
Fax +39 049 706692
www.profilpas.com

DURAL GmbH & Co.

Via Oberdan, 11
40126 Bologna (BO) - Italia
Tel. +39 051 0971513
Fax +39 051 0971513
www.dural.com

WEDI ITALIA S.r.l.

Via Redipuglia, 32
20035 Lissone (MI) - Italia
Tel. +39 0392 459420
www.wedi.it

RARE S.r.l

Via delle Brughiere, 12
21050 Cairate (VA) - Italia
Tel. +39 0331 360360
Fax +39 0331 360168
www.rareboxdoccia.com

Tile cutters / Glass cutters Abrasive sponges

BOHLE ITALIA S.r.l.

Via Cavallotti, 28
20081 Abbiategrasso (MI) - Italia
Tel. +39 02 94967790
Fax +39 02 94609011
e-mail Italia@Bohle.de

WÜRTH S.r.l.

Via Stazione, 51
39044 Egna (BZ) - Italia
Tel. +39 06 90779001
Fax +39 06 90386201
e-mail clienti@wuertth.it

Tile cutter rulers

SIGMA S.n.c.

Via A. Gagliani, 4
47813 Igea Marina Bellaria (RN) - Italia
Tel. +39 0541 330103
Fax +39 0541 330422
e-mail info@sigmaitalia.com

RAIMONDI S.r.l.

Via dei tipografi, 11
41100 Modena (MO) - Italia
Tel. +39 059 280888
Fax +39 059 282808
www.raimondiutensili.it

Detergents

MAPEI S.p.A.

Via Cafiero 22
20158 (MI) - Italia
Tel. +39 02 37673
www.mapei.it

FABERCHIMICA S.r.l.

via G. Ceresani, 10 - Località Campo d'Olmo
60044 Fabriano (AN) - Italia
Tel. +39 0732 627178
www.faberchimica.com

FILA Industria Chimica S.p.A.

via Garibaldi, 32
35018 S. Martino dei Lupari (PD) - Italia
Tel. +39 049 9467300
www.filachim.it

Detergents

ZEP Italia S.r.l.

via Nettunese, Km 25,000
04011 Aprilia (LT) - Italia
Tel. +39 06 926691
www.zepitalia.it

JOHNSON DIVERSEY S.p.A.

via Meucci, 40
20128 Milano - Italia
Tel. +39 0373 2051
www.johnsondiversey.com

KITER S.r.l.

via Assiano, 7/B
20019 Settimo Milanese (MI) - Italia
Tel. +39 02 3285220
www.kiter.it

GEAL S.r.l.

via Settola, 121
51031 Agliana (PT) - Italia
Tel. +39 0574 750365
www.geal-chim.it

FEDERCHEMICALS S.r.l.

via G. Borsi, 2
25128 - Brescia - Italia
Tel. +39 030 3390880
Fax +39 030 3385580
www.federchemicals.it

LITHOFIN-Produkte GmbH

Postfach 1134,
D-73236 Wendlingen (D)
Tel. 0049 07024/940320
www.lithofin.de
Vertrieb für Österreich:
CT-Austria Ges.m.b.H. A-1230 Wien
Tel. +43 01 8673434

HMK - MÖLLER-CHEMIE

Benelux GmbH - Linge 4
NL-2105 WB Heemstede (NL)
Tel. +31 0252 220222
www.moellerchemie.de

BONASYSTEMS ITALIA S.r.l.

Via Borgo S. Chiara, 29
30020 Torre di Mosto (VE) - Italia
Tel. +39 0421 325691
Fax +39 0421 324232
www.bonasytemsitalia.it

Notched and rubber coated trowels

RAIMONDI S.r.l.

Via dei tipografi, 11
41100 Modena (MO) - Italia
Tel. +39 059 280888
Fax +39 059 282808
www.raimondiutensili.it

Plaster

FASSA BORTOLO S.p.A.

via Lazzaris, 3
31027 Spresiano (TV) - Italia
Tel. +39 0422 7222
Fax +39 0422 887509
www.fassabortolo.com

GRIGOLIN S.p.A.

Via IV Novembre, 18
31010 Ponte della Priula (TV) - Italia
Tel. +39 0438 4461
Fax +39 0438 445110
www.gruppogrigin.it

Cutting discs / diamond and abrasive discs / Drill bits

DIAMANT CENTER - TYROLIT S.r.l.

Via Valle d'Aosta, 12
41049 Sassuolo (MO) - Italia
Tel. +39 0536 808166
Fax +39 0536 808211
www.diamantcenter.it

MONTOLIT S.p.A.

Via Turconi, 25
21050 Cantello (VA) - Italia
Tel. +39 0332 419211/417744
e-mail info@montolit.com
www.montolit.com

RAIMONDI S.r.l.

Via dei tipografi, 11
41100 Modena (MO) - Italia
Tel. +39 059 280888
Fax +39 059 282808
www.raimondiutensili.it

Cutting discs / diamond and abrasive discs / Drill bits

RUBI ITALIA S.r.l.

Via Radici in Piano, 596/A
41049 Sassuolo (MO) - Italia
Tel. +39 0536 810984
Fax +39 0536 810987
e-mail rubitalia@rubi.com

WÜRTH S.r.l.

Via Stazione, 51
39044 Egna (BZ) - Italia
Tel. +39 06 90779001
Fax +39 06 90386201
e-mail clienti@wuertth.it

Decoupling mats, acoustic, etc.

SCHLÜTER-SYSTEMS Italia S.r.l.

Via Bucciardi 31/33
41042 Fiorano Modenese (MO)
Tel. +39 0536 914511
Fax +39 0536 911156
www.schlueter.it

GUTJAHR Systemtechnik GmbH

Philipp-Reis-Str. 5-7
D-64404 Bickenbach/Bergstraße
Tel. +49 0 62 57 - 93 06-0
Fax +49 0 62 57 - 93 06-31
www.gutjahr.com

Adhesives attachment



It is essential to follow all instructions given by adhesive manufacturers. This applies in particular to waiting time running before a surface can be walked on or grouted and the "Ready to use" time shown in the following tables.

As a general rule that applies for all building materials to be secured in place with adhesive, there is no universal adhesive for installing KERLITE on all kinds of surface.

Since it is not possible to describe all possible cases, we have provided information about the most common situations. First of all, we have divided installation cases into "walls" and "floors" and then into "interior" and "exterior". Depending on the rated stress, on any work to be performed subsequently and on the maximum dimension of the slab, we have assigned a certain type of KERLITE to each category. Starting from this classification, we have thus examined the most common kinds of supporting material. The resulting chart has been sent to all main manufacturers of adhesive that have, in turn, provided the most suitable product for each category.

Please note that all solutions suggested have been submitted by adhesive manufacturers, who guarantee the indications given. For explanations or more information, contact the respect manufacturers (see "9 - Handy addresses").

It is essential to follow all instructions given by adhesive manufacturers. This applies in particular to waiting time running before a surface can be walked on or grouted and the "Ready to use" time shown in the following tables.



Wall installation

 Interiors	In situations where holes and cuts are NOT necessary and with sizes up to 100 x 100 cm.	KERLITE	Two-coat plaster, gypsum plaster, plasterboard, fibre cement panels	Page 36
			Concrete, old ceramic tile, marble, stone	Page 37
			Particle board, metal	Page 38
 Interiors	In situations where holes and cuts are necessary.	KERLITE PLUS	Two-coat plaster, gypsum plaster, plasterboard, fibre cement panels	Page 39
			Concrete, old ceramic tile, marble, stone	Page 40
			Particle board, metal	Page 41
 Exteriors	In situations where holes and cuts are NOT necessary and with sizes up to 100 x 100 cm.	KERLITE	Plaster	Page 42
			Concrete	Page 43
	In situations where holes and cuts are necessary and/or for large sizes.	KERLITE PLUS	Plaster	Page 44
			Concrete	Page 45

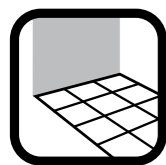

Floor installation

 Interiors	In any situation with the exception of areas subject to heavy loads (e.g. trolleys with hard wheels).	KERLITE PLUS	Cement-based screeds, calcium sulphate-based or heated screeds, self-levelling products, concrete, old ceramic tile, marble slabs, stone	Page 46
			Wood, PVC, rubber, linoleum, metal, resin	Page 47
 Exteriors	Upon condition that surfaces are sheltered (e.g. loggias, covered balconies, etc.) and made totally impervious.	KERLITE PLUS	Cement-based screeds, calcium sulphate-based or heated screeds, self-levelling products, concrete, old ceramic tile, marble slabs, stone	Page 46
			Wood, PVC, rubber, linoleum, metal, resin	Page 47

How to read the attachment

At the discretion of I.S.	Manufacturer	Size of slabs (cm)	Product (*)	Primer, if necessary (*)	Mixing ratio (**)	Class (*)	Nominal coverage (*)	Setting for foot traffic and workability (***)	Ready for use (***)	Installation (*)
01	02	03	04	05	06	07	08	09	10	11

01_ The installation supervisor must examine the conditions of the work site to choose between a normal setting adhesive or a quick setting adhesive.

02_ Adhesive manufacturers.

03_ Depending on the adhesive recommended by the manufacturer, you will find the size in cm of the slab.

04_ List of adhesives recommended by manufacturers based on the intended use and size of the slabs.

05_ List of primers to use before adhesive application, as indicated by manufacturers for each intended use.

06_ The mixing ratio refers to a single product unit (a bag, a can, etc.), in order to obtain the characteristics declared by manufacturers.

07_ The adhesive's class under the UNI EN 12004 standard is indicated. (see "About ADHESIVES" below).

08_ You will find an indication of how many square metres you can install with a single product unit prepared with the established mixing ratio.

09_ You will find the time you must wait before treading on the surface to fill joints with grout.

10_ You will find the time that must pass before using the floor, i.e. before it can go subject to static and/or dynamic stress.

11_ You will find the installation method and features of the trowel to use for each adhesive.

About ADHESIVES

Adhesives are divided into THREE CLASSES, depending on their composition, as established by the UNI EN 12004 standard:

CEMENTITIOUS (C): mixture of hydraulic binding agents, aggregates and organic additives (note to be mixed with water or other liquid additive immediately before use)

REACTIVE (R): mixture of synthetic resin, mineral fillers and organic additives, which harden due to a chemical reaction (note: these adhesives may have one or more components)

DISPERSION (D): mixture of binding and organic agents, namely polymers in aqueous dispersion, organic additives and mineral fillers (note: ready-to-use mixtures)

Depending on their features, adhesives are thus classified:

Class 1: normal setting

Class 2: improved setting properties

There are three additional classes:

Class F: quick setting adhesives

Class T: slip resistant adhesives

Class E: adhesives with extended open time

There is a fourth additional class for cementitious adhesives only: adhesives can be classified as DEFORMABLE (S) and divided on the basis of test results under the UNI EN 12002 standard:



Class S1: deformable adhesives

Class S2: highly deformable adhesives

A.1a - Interior wall installation of KERLITE



Supporting material: two-coat plaster, gypsum plaster, plasterboard, fibre cement panels.

At the discretion of I.S.	Manufacturer	Size of slabs (cm)	Product (*)	Primer, if necessary (*)	Mixing ratio (**)	Class (*)	Nominal coverage (*)	Workability (***)	Ready for use (***)	Installation (*)	
 For situations in which a normal setting adhesive is recommended	MAPEI	50x50; 100x40; 100x50	KERAFLEX MAXI S1	Compulsory for gypsum-based, anhydride or absorbent surfaces: Primer G or ECOPRIM T	1 bag (25 kg) + 7.2/7.7 litres of water	C2 TE S1	7 m ²	8 hours	14 days	Installation with a double layer of adhesive	
			ULTRALITE S1		1 bag (15 kg) + 8.4/8.7 litres of water	C2 TE S1					
		100x100; 300x100	ULTRALITE S2		1 bag (15 kg) + 5.9/6.2 litres of water	C2 E S2	6,3 m ²				
			KERABOND + ISOLASTIC		1 bag (25 kg) + 8.5 kg of ISOLASTIC	C2 E S2	6,5 m ²				
	KERAKOLL	All sizes	H40 Eco Flex	For gypsum-based surfaces: Primer A Eco	1 bag (25 kg) + 6.5 litres of water	C2 E	6 m ²	5 m ²	8 hours		7 days
			H40 Eco Tenaflex		1 bag (25 kg) + 8 litres of water	C2 TE					
		for plasterboard and fibre cement panel ONLY, all sizes	H40 Eco Ideal	Not necessary, according to manufacturer	1 bag (25 kg) + 8.2 litres of water	C2 TE	6 m ²				
			H40 Eco Extraflex		1 bag (25 kg) + 8 litres of water	C2 TE S1	6 m ²				
	LATICRETE	All sizes	LATICRETE 254 Platinum	Not necessary, according to manufacturer	1 bag (25 kg) + 6 litres of water	C2 TE S1	5 m ²	1 day	14 days		
	LITOKOL	All sizes	SUPERFLEX K77	For gypsum-based surfaces: Primer C	1 bag (25 kg) + 8.5 litres of water	C2 TE S1	6 m ²	8 hours	14 days		
	PCI - BASF	All sizes	PCI NANOLIGHT	For gypsum-based surfaces: PCI GISOGRUND	1 bag (15 kg) + 9 litres of water	C2 TE S1	5,5 m ²	8 hours	1 day		
	SAINT-GOBAIN / WEBER	All sizes	WEBER.COL PRO HP	For gypsum-based surfaces: WEBER.PRIM PF15	1 bag (25 kg) + 7 litres of water	C2 TE S1	5 m ²	8 hours	14 days		
			WEBER.COL PRO HF LIGHT		1 bag (15 kg) + 8 litres of water	C2 TE S2					
	ARDEX	All sizes	ARDEX X 77 Microtec	For gypsum-based surfaces: ARDEX P 51	1 bag (25 kg) + 11 litres of water	C2(T) E(E) S1	10 m ²	8 hours	1 day		Installation with a single layer of adhesive (6 mm trowel)
 For situations in which a quick setting adhesive is recommended	MAPEI	50x50; 100x40; 100x50	GRANIRAPID	COMPULSORY for gypsum-based, anhydride or absorbent surfaces: Primer G or ECOPRIM T	Component A: 1 bag (25 kg) Component B: tub (5.5 kg)	C2 F S1	6 m ²	3 hours	1 day	Installation with a double layer of adhesive	
			ULTRALITE S1 QUICK		1 bag (15 kg) + 5.1/5.7 litres of water	C2 FTE S1					
		100x100; 300x100	ULTRALITE S2 QUICK		Component A: 1 bag (25 kg) Component B: tub (6.5 kg)	C2 FTE S2	6 m ²				
			ELASTORAPID		1 bag (25 kg) + 7.3 litres of water	C2F TE	5 m ²				
	KERAKOLL	For plasterboard and fibre cement panels only, all sizes	H40 Eco rapid	For gypsum-based surfaces: Primer A Eco	1 bag (25 kg) + 7.3 litres of water	C2F TE	5 m ²	3 hours	2 days		
			H40 Eco Rapidflex		Not necessary, according to manufacturer	1 bag (25 kg) + 6.3 litres of water	C2F TE S1				6 m ²
	LATICRETE	All sizes	LATICRETE 335 Rapid Super Flex + LATICRETE 282 Latex Additive	Not necessary, according to manufacturer	1 bag (25 kg) + 6/7 litres of latex	C2 TE F	5 m ²	6 hours	2 days		
	LITOKOL	All sizes	LITOSTONE K99 + LATEXKOL + water	For gypsum-based surfaces: Primer C	1 bag (25 kg) + 3.5 litres of LATEXKOL + 3.5 litres of water	C2 FE S1	5 m ²	4 hours	1 day		
	PCI - BASF	All sizes	PCI NANOLIGHT	For gypsum-based surfaces: PCI GISOGRUND	1 bag (15 kg) + 9 litres of water	C2 TE S1	5,5 m ²	8 hours	1 day		
	ARDEX	All sizes	ARDEX X 77 S microtec	For gypsum-based surfaces: ARDEX P 51	1 bag (25 kg) + 8.5 litres of water	C2 FT(T) E S1	10 m ²	90 min.	6 hours		Installation with a single layer of adhesive (6 mm trowel)

(*) Instructions provided directly by manufacturers, who guarantee the information given. For explanations or more details, contact the technical support offices of the respective manufacturers (see "9 - handy addresses").



(**) Instructions provided directly by manufacturers, who guarantee the information given. If a product is offered in both "white" and a "grey" versions, the mixing ratio may vary. For explanations or more details, contact the technical support offices of the respective manufacturers (see "9 - handy addresses").

(***) Ratings provided directly by manufacturers, who guarantee the information given, are based on laboratory tests performed at 23° C and with a relative humidity of 50%. In the event of use in different situations or for explanations or more details, contact the technical support offices of the respective manufacturers (see "9 - handy addresses").

A.1b - Wall installation of KERLITE in interiors



Supporting material: concrete, old ceramic tile, marble, stone

At the discretion of I.S.	Manufacturer	Size of slabs (cm)	Product (*)	Primer, if necessary (*)	Mixing ratio (**)	Class (*)	Nominal coverage (*)	Workability (***)	Ready for use (***)	Installation (*)		
 For situations in which a normal setting adhesive is recommended	MAPEI	50x50; 100x40; 100x50	KERAFLEX MAXI S1	If levelling is necessary, on the above mentioned supports, apply the following product beforehand ECOPRIM GRIP	1 bag (25 kg) + 7.2/7.7 litres of water	C2 TE S1	7 m ²	8 hours	14 days	Installation with a double layer of adhesive		
			ULTRALITE S1		1 bag (15 kg) + 8.4/8.7 litres of water	C2 TE S1						
		100x100; 300x100	ULTRALITE S2		1 bag (15 kg) + 5.9/6.2 litres of water	C2 E S2	6,3 m ²					
			KERABOND + ISOLASTIC		1 bag (25 kg) + 8.5 kg of ISOLASTIC	C2 E S2	6,5 m ²					
	KERAKOLL	All sizes	H40 Eco Flex	Not necessary, according to manufacturer	1 bag (25 kg) + 6.5 litres of water	C2 E	5 m ²	8 hours	7 days			
			H40 Eco Tenaflex		1 bag (25 kg) + 8 litres of water	C2 TE						
	LATICRETE	All sizes	LATICRETE 254 Platinum	Not necessary, according to manufacturer	1 bag (25 kg) + 6 litres of water	C2 TE S1	5 m ²	1 day	7 days			
	LITOKOL	All sizes	SUPERFLEX K77	Not necessary, according to manufacturer	1 bag (25 kg) + 8.5 litres of water	C2 TE S1	6 m ²	8 hours	7 days			
	PCI - BASF	All sizes	PCI NANOLIGHT	On non-absorbent supports: PCI GISOGRUND 303	1 bag (15 kg) + 9 litres of water	C2 TE S1	5,5 m ²	8 hours	1 day			
	SAINT-GOBAIN / WEBER	All sizes	WEBER.COL PRO HP	For old ceramic tile, marble slabs and stone: WEBER.PRIM PF16	1 bag (25 kg) + 7 litres of water	C2 TE S1	5 m ²	8 hours	14 days			
			WEBER.COL PRO HF LIGHT		1 bag (15 kg) + 8 litres of water	C2 TE S2						
	ARDEX	All sizes	ARDEX X 77 Microtec	As an alternative for old ceramic tile, marble slabs and stone: ARDEX P 4 - ARDEX X 77 (rough levelled)	1 bag (25 kg) + 11 litres of water	C2(T) E(E) S1	10 m ²	8 hours	1 day		Installation with a single layer of adhesive (6 mm trowel)	
	 For situations in which a quick setting adhesive is recommended	MAPEI	50x50; 100x40; 100x50	GRANIRAPID	If levelling is necessary, on the above mentioned supports, apply the following product beforehand ECOPRIM GRIP	Component A: 1 bag (25 kg) Component B: tub (5.5 kg)	C2 F S1	6 m ²	3 hours		1 day	Installation with a double layer of adhesive
				ULTRALITE S1 QUICK		1 bag (15 kg) + 5.1/5.7 litres of water	C2 FTE S1					
100x100; 300x100			ULTRALITE S2 QUICK	Component A: 1 bag (25 kg) Component B: tub (6.5 kg)		C2 FTE S2	6 m ²					
			ELASTORAPID	1 bag (25 kg) + 7.3 litres of water		C2F TE	5 m ²					
KERAKOLL		All sizes	H40 Eco rapid	Not necessary, according to manufacturer	1 bag (25 kg) + 7.3 litres of water	C2F TE	6 m ²	3 hours	2 days			
LATICRETE		All sizes	LATICRETE 335 Rapid Super Flex + LATICRETE 282 Latex Additive	Not necessary, according to manufacturer	1 bag (25 kg) + 6/7 litres of latex	C2 TE F	5 m ²	6 hours	2 days			
LITOKOL		All sizes	LITOSTONE K99 + LATEXKOL + water	For gypsum-based surfaces: Primer C	1 bag (25 kg) + 3.5 litres of LATEXKOL + 3.5 litres of water	C2 FE S1	5 m ²	4 hours	1 day			
PCI - BASF		All sizes	PCI NANOLIGHT	On non-absorbent supports: PCI GISOGRUND 303	1 bag (15 kg) + 9 litres of water	C2 TE S1	5,5 m ²	8 hours	1 day			
ARDEX		All sizes	ARDEX X 77 S microtec	As an alternative for old ceramic tile, marble slabs and stone: ARDEX P 4 - ARDEX X 77 (rough levelled)	1 bag (25 kg) + 8.5 litres of water	C2 FT(T) E S1	10 m ²	90 min.	6 hours	Installation with a single layer of adhesive (6 mm trowel)		

(*) Instructions provided directly by manufacturers, who guarantee the information given. For explanations or more details, contact the technical support offices of the respective manufacturers (see "9 - handy addresses").

(**) Instructions provided directly by manufacturers, who guarantee the information given. If a product is offered in both "white" and a "grey" versions, the mixing ratio may vary. For explanations or more details, contact the technical support offices of the respective manufacturers (see "9 - handy addresses").

(***) Ratings provided directly by manufacturers, who guarantee the information given, are based on laboratory tests performed at 23° C and with a relative humidity of 50%. In the event of use in different situations or for explanations or more details, contact the technical support offices of the respective manufacturers (see "9 - handy addresses").

A.1c - Wall installation of KERLITE in interiors



Supporting material: particle board, metal

At the discretion of I.S.	Manufacturer	Size of slabs (cm)	Product (*)	Primer, if necessary (*)	Mixing ratio (**)	Class (*)	Nominal coverage (*)	Workability (***)	Ready for use (***)	Installation (*)
<p>For situations in which a normal setting adhesive is recommended</p>	MAPEI	All sizes	KERALASTIC	Not necessary, according to manufacturer	1 can (10 kg)	R2	3 m ²	12 hours	7 days	Installation with a double layer of adhesive
			KERALASTIC T		1 can (10 kg)	R2T				
	KERAKOLL	All sizes	SUPERFLEX ECO	Not necessary, according to manufacturer	1 bucket (8 kg)	R2T	3 m ²	12 hours	3 days	
	LATICRETE	All sizes	LATALASTIK	Not necessary, according to manufacturer	1 bucket of component A (5 kg) 1 bucket of component B (2 kg)	R2T	3 m ²	1 day	7 days	
	LITOKOL	All sizes	LITOELASTIC	Not necessary, according to manufacturer	1 bucket (10 kg)	R2T	3 m ²	12 hours	5 days	
	PCI - BASF	All sizes	PCI NANOLIGHT	Use of the following product is compulsory: PCI GISOGRUN 303	1 bag (15 kg) + 9 litres of water	C2 TE S1	5,5 m ²	8 hours	1 day	
	SAINT-GOBAIN / WEBER	All sizes	FIX CR	Not necessary, according to manufacturer	1 bucket (10 kg)	R2	3 m ²	12 hours	2 days	
ARDEX	All sizes	ARDEX X 77 microtec	ARDEX P 82	1 bag (25 kg) + 11 litres of water	C2 T(T) E(E) S1	10 m ²	8 hours	1 day		
<p>For situations in which a quick setting adhesive is recommended</p>	MAPEI	All sizes	KERAQUICK + LATEX PLUS	Not necessary, according to manufacturer	1 bag (25 kg) + 8.5 kg of LATEX PLUS	C2 FT S2	7 m ²	3 hours	1 day	Installation with a double layer of adhesive
	KERAKOLL	All sizes	SUPERFLEX ECO	Not necessary, according to manufacturer	1 bucket (8 kg)	R2T	3 m ²	12 hours	3 days	
	LATICRETE	All sizes	LATALASTIK	Not necessary, according to manufacturer	1 bucket of component A (5 kg) 1 bucket of component B (2 kg)	R2T	2 m ²	1 day	7 days	Installation with a single layer of adhesive (6 mm trowel)
	LITOKOL	All sizes	LITOELASTIC	Not necessary, according to manufacturer	1 bucket (10 kg)	R2T	3 m ²	12 hours	5 days	Installation with a double layer of adhesive
	PCI - BASF	All sizes	PCI NANOLIGHT	Use of the following product is compulsory: PCI GISOGRUN 303	1 bag (15 kg) + 9 litres of water	C2 TE S1	5,5 m ²	8 hours	1 day	
ARDEX	All sizes	ARDEX X 77 S microtec	ARDEX P 82	1 bag (25 kg) + 8.5 litres of water	C2 FT(T) E S1	10 m ²	90 min.	6 hours	Installation with a single-layer of adhesive (6 mm trowel)	

(*) Instructions provided directly by manufacturers, who guarantee the information given. For explanations or more details, contact the technical support offices of the respective manufacturers (see "9 - handy addresses").

(**) Instructions provided directly by manufacturers, who guarantee the information given. If a product is offered in both "white" and a "grey" versions, the mixing ratio may vary. For explanations or more details, contact the technical support offices of the respective manufacturers (see "9 - handy addresses").

(***) Ratings provided directly by manufacturers, who guarantee the information given, are based on laboratory tests performed at 23° C and with a relative humidity of 50%. In the event of use in different situations or for explanations or more details, contact the technical support offices of the respective manufacturers (see "9 - handy addresses").

A.2a - Wall installation of KERLITE PLUS in interiors



Supporting material: two-coat plaster, gypsum plaster, plasterboard, fibre cement panels

At the discretion of I.S.	Manufacturer	Size of slabs (cm)	Product (*)	Primer, if necessary (*)	Mixing ratio (**)	Class (*)	Nominal coverage (*)	Workability (***)	Ready for use (***)	Installation (*)	
<p>For situations in which a normal setting adhesive is recommended</p>	MAPEI	50x50; 100x40; 100x50	KERAFLEX MAXI S1	COMPULSORY for gypsum-based, anhydride or absorbent surfaces: Primer G or ECOPRIM T	1 bag (25 kg) + 7.2/7.7 litres of water	C2 TE S1	7 m ²	8 hours	14 days	Installation with a double layer of adhesive	
			ULTRALITE S1		1 bag (15 kg) + 8.4/8.7 litres of water	C2 TE S1					
		100x100; 300x100	ULTRALITE S2		1 bag (15 kg) + 5.9/6.2 litres of water	C2 E S2	6,3 m ²				
			KERABOND + ISOLASTIC		1 bag (25 kg) + 8.5 kg of ISOLASTIC	C2 E S2	6,5 m ²				
	KERAKOLL	All sizes	H40 Eco flex	For gypsum-based surfaces: Primer A Eco	1 bag (25 kg) + 6.5 litres of water	C2 E	5 m ²	8 hours	7 days		
			H40 Eco tenaflex		1 bag (25 kg) + 8 litres of water	C2 TE					
		For gypsum-based plaster ONLY, all sizes	H40 Eco ideal	Not necessary, according to manufacturer	1 bag (25 kg) + 8.2 litres of water	C2 TE					
	LITOKOL	All sizes	for plasterboard and fibre cement panel ONLY, all sizes	H40 Eco Extraflex	Not necessary, according to manufacturer	1 bag (25 kg) + 7.5 litres of water	C2 TE S1	5 m ²	8 hours		7 days
						1 bag (25 kg) + 8.2 litres of water	C2 TE S1				
	LATICRETE	All sizes	LATICRETE 254 Platinum	Not necessary, according to manufacturer	1 bag (25 kg) + 6 litres of water	C2 TE S1	5 m ²	1 day	7 days		
LITOKOL	50x50; 100x40; 100x50	100x100; 300x100	SUPERFLEX K77	For gypsum-based surfaces: Primer C	1 bag (25 kg) + 8.5 litres of water	C2 TE S1	6 m ²	8 hours	7 days		
			CEMENTKOL K21 + LATEXKOL		1 bag (25 kg) + 7.5 kg of LATEXKOL	C2 S2	5 m ²				
PCI - BASF	All sizes	PCI NANOLIGHT + PCI LASTOFLEX	For gypsum-based surfaces: PCI GISOGRUND	1 bag (15 kg) + 1 can of PCI LASTOFLEX (4 kg) + 5 litres of water	C2 TE S2	5,5 m ²	8 hours	1 day			
SAINT-GOBAIN / WEBER	All sizes	All sizes	WEBER.COL PRO HP	For gypsum-based surfaces: WEBER.PRIM PF15	1 bag (25 kg) + 7 litres of water	C2 TE S1	5 m ²	2 days	14 days		
			WEBER.COL PRO HF LIGHT		1 bag (15 kg) + 8 litres of water	C2 TE S2		8 hours			
ARDEX	All sizes	ARDEX X 77 microtec + ARDEX E 90	For gypsum-based surfaces: ARDEX P 51	1 bag (25 kg) + 1 can of ARDEX E 90 (4.5 kg) + 9 litres of water	C2 T(T) E(E) S2	10 m ²	8 hours	1 day	Installation with a single layer of adhesive (6 mm trowel)		
<p>For situations in which a quick setting adhesive is recommended</p>	MAPEI	50x50; 100x40; 100x50	GRANIRAPID	COMPULSORY for gypsum-based, anhydride or absorbent surfaces: Primer G or ECOPRIM T	Component A: 1 bag (25 kg) Component B: tub (5.5 kg)	C2 F S1	6 m ²	3 hours	1 day	Installation with a double layer of adhesive	
			ULTRALITE S1 QUICK		1 bag (15 kg) + 5.1/5.7 litres of water	C2 F TE S1					
		100x100; 300x100	ULTRALITE S2 QUICK		1 bag (15 kg) + 5.1/5.7 litres of water	C2 FE S2	7 m ²				
			ELASTORAPID		Component A: 1 bag (25 kg) Component B: tub (6.5 kg)	C2 F TE S2	6 m ²				
	KERAKOLL	All sizes	for plasterboard and fibre cement panel ONLY, all sizes	H40 Eco rapid	For gypsum-based surfaces: Primer A Eco	1 bag (25 kg) + 7.3 litres of water	C2 F TE	5 m ²	3 hours		2 days
				H40 Eco Rapidflex		Not necessary, according to manufacturer	1 bag (25 kg) + 6.3 litres of water	C2 F TE S1			
	LATICRETE	All sizes	LATICRETE 335 Rapid Super Flex + LATICRETE 282 Latex Additive	Not necessary, according to manufacturer	1 bag (25 kg) + 6/7 litres of latex	C2 TE F	5 m ²	6 hours	2 days		
	LITOKOL	50x50; 100x40; 100x50	100x100; 300x100	LITOSTONE K99 + LATEXKOL + water	For gypsum-based surfaces: Primer C	1 bag (25 kg) + 3.5 litres of LATEXKOL + 3.5 litres of water	C2 FE S1	5 m ²	4 hours		1 day
				LITOSTONE K99 + LATEXKOL		1 bag (25 kg) + 7.5 kg of LATEXKOL	C2 FE S2				
	PCI - BASF	All sizes	PCI NANOLIGHT + PCI LASTOFLEX	For gypsum-based surfaces: PCI GISOGRUND	1 bag (15 kg) + 1 can of PCI LASTOFLEX (4 kg) + 5 litres of water	C2 TE S2	5,5 m ²	8 hours	1 day		
ARDEX	All sizes	ARDEX X 77 S microtec + ARDEX E 90	For gypsum-based surfaces: ARDEX P 51	1 bag (25 kg) + 3 kg of ARDEX E 90 + 6 litres of water	C2 FT(T) E S2	10 m ²	90 min.	6 hours	Installation with a single layer of adhesive (6 mm trowel)		

(*) Instructions provided directly by manufacturers, who guarantee the information given. For explanations or more details, contact the technical support offices of the respective manufacturers (see "9 - handy addresses").

(**) Instructions provided directly by manufacturers, who guarantee the information given. If a product is offered in both "white" and a "grey" versions, the mixing ratio may vary. For explanations or more details, contact the technical support offices of the respective manufacturers (see "9 - handy addresses").

(***) Ratings provided directly by manufacturers, who guarantee the information given, are based on laboratory tests performed at 23° C and with a relative humidity of 50%. In the event of use in different situations or for explanations or more details, contact the technical support offices of the respective manufacturers (see "9 - handy addresses").

A.2b - Wall installation of KERLITE PLUS in interiors



Supporting material: concrete, old ceramic tile, marble, stone

At the discretion of I.S.	Manufacturer	Size of slabs (cm)	Product (*)	Primer, if necessary (*)	Mixing ratio (**)	Class (*)	Nominal coverage (*)	Workability (***)	Ready for use (****)	Installation (*)
 For situations in which a normal setting adhesives is recommended	MAPEI	50x50; 100x40; 100x50	KERAFLEX MAXI S1	If levelling is necessary, on the above mentioned supports, apply the following product beforehand ECOPRIM GRIP	1 bag (25 kg) + 7.2/7.7 litres of water	C2 TE S1	7 m ²	8 hours	14 days	Installation with a double layer of adhesive
			ULTRALITE S1		1 bag (15 kg) + 8.4/8.7 litres of water	C2 TE S1				
		100x100; 300x100	ULTRALITE S2		1 bag (15 kg) + 5.9/6.2 litres of water	C2 E S2	6,3 m ²			
			KERABOND + ISOLASTIC		1 bag (25 kg) + 8.5 kg of ISOLASTIC	C2 E S2	6,5 m ²			
	KERAKOLL	All sizes	H40 Eco flex	Not necessary, according to manufacturer	1 bag (25 kg) + 6.5 litres of water	C2 E	5 m ²	8 hours	7 days	
			H40 Eco tenaflex		1 bag (25 kg) + 8 litres of water	C2 TE				
	LATICRETE	All sizes	LATICRETE 254 Platinum	Not necessary, according to manufacturer	1 bag (25 kg) + 6 litres of water	C2 TE S1	5 m ²	1 day	7 days	
	LITOKOL	50x50;100x40; 100x50	SUPERFLEX K77	Not necessary, according to manufacturer	1 bag (25 kg) + 8.5 litres of water	C2 TE S1	6 m ²	8 hours	7 days	
			100x100; 300x100		CEMENTKOL K21 + LATEXKOL	1 bag (25 kg) + 7.5 kg of LATEXKOL	C2 S2			
	PCI - BASF	All sizes	PCI NANOLIGHT + PCI LASTOFLEX	On non-absorbent supports PCI GISOGRUN 303	1 bag (15 kg) + 1 can of PCI LASTOFLEX (4 kg) + 5 litres of water	C2 TE S2	5,5 m ²	8 hours	1 day	
SAINT-GOBAIN / WEBER	All sizes	WEBER.COL PRO HP	For old ceramic tile, marble slabs and stone: WEBER.PRIM PF16	1 bag (25 kg) + 7 litres of water	C2 TE S1	5 m ²	2 days	14 days		
		WEBER.COL PRO HF LIGHT		1 bag (15 kg) + 8 litres of water	C2 TE S2		8 hours			
ARDEX	All sizes	ARDEX X 77 microtec + ARDEX E 90	As an alternative for old ceramic tile, marble slabs and stone: - A 4 -X 77)	1 bag (25 kg) + 1 can of ARDEX E 90 (4.5 kg) + 9 litres of water	C2(T) E(E) S2	10 m ²	8 hours	1 day	Installation with a single layer of adhesive (6 mm trowel)	
 For situations in which a quick setting adhesive is recommended	MAPEI	50x50; 100x40; 100x50	GRANIRAPID	If levelling is necessary, on the above mentioned supports, apply ECOPRIM GRIP beforehand	Component A: 1 bag (25 kg) Component B: tub (5.5 kg)	C2 F S1	6 m ²	3 hours	1 day	Installation with a double layer of adhesive
			ULTRALITE S1 QUICK		1 bag (15 kg) + 5.1/5.7 litres of water	C2 FTE S1				
		100x100; 300x100	ULTRALITE S2 QUICK		1 bag (15 kg) + 5.1/5.7 litres of water	C2 FE S2	7 m ²			
			ELASTORAPID		Component A: 1 bag (25 kg) Component B: tub (6.5 kg)	C2 FTE S2	6 m ²			
	KERAKOLL	All sizes	H40 Eco rapid	Not necessary, according to manufacturer	1 bag (25 kg) + 7.3 litres of water	C2F TE	6 m ²	3 hours	2 days	
	LATICRETE	All sizes	LATICRETE 335 Rapid Super Flex + LATICRETE 282 Latex Additive	Not necessary, according to manufacturer	1 bag (25 kg) + 6/7 litres of latex	C2 TE F	5 m ²	6 hours	2 days	
	LITOKOL	50x50;100x40; 100x50	LITOSTONE K99 + LATEXKOL + water	For gypsum-based surfaces: Primer C	1 bag (25 kg) + 3.5 litres of LATEXKOL + 3.5 litres of water	C2 FE S1	5 m ²	4 hours	1 day	
			100x100; 300x100		LITOSTONE K99 + LATEXKOL	1 bag (25 kg) + 7.5 kg of LATEXKOL				
	PCI - BASF	All sizes	PCI NANOLIGHT + PCI LASTOFLEX	On non-absorbent supports PCI GISOGRUN 303	1 bag (15 kg) + 1 can of PCI LASTOFLEX (4 kg) + 5 litres of water	C2 TE S2	5,5 m ²	8 hours	1 day	
	ARDEX	All sizes	ARDEX X 77 S microtec + ARDEX E 90	As an alternative for old ceramic tile, marble slabs and stone: - A 4 -X 77)	1 bag (25 kg) + 3 kg of ARDEX E 90 + 6 litres of water	C2 FT(T) ES2	10 m ²	90 min.	6 hours	

(*) Instructions provided directly by manufacturers, who guarantee the information given. For explanations or more details, you can contact the technical support offices of the respective manufacturers (see "9 - handy addresses").
 (**) Instructions provided directly by manufacturers, who guarantee the information given. If a product is offered in both "white" and a "grey" versions, the mixing ratio may vary. For explanations or more details, you can contact the technical support offices of the respective manufacturers (see "9 - handy addresses").
 (****) Ratings provided directly by manufacturers, that guarantee the information given, based on laboratory tests performed at 23° C and with a relative humidity of 50%. For use in different situations, contact the technical support office of the respective manufacturers. For explanations or more details, you can contact the technical support offices of the respective manufacturers (see "9 - handy addresses").

A.2c - Wall installation of KERLITE PLUS in interiors



Supporting material: particle board, metal



At the discretion of I.S.	Manufacturer	Size of slabs (cm)	Product (*)	Primer, if necessary (*)	Mixing ratio (**)	Class (*)	Nominal coverage (*)	Workability (***)	Ready for use (****)	Installation (*)
 For situations in which a normal setting adhesives is recommended	MAPEI	All sizes	KERALASTIC	Not necessary, according to manufacturer	1 can (10 kg)	R2	3 m ²	12 hours	7 days	Installation with a single-layer of adhesive (6 mm trowel)
			KERALASTICT			R2T				
	KERAKOLL	All sizes	SUPERFLEX ECO	Not necessary, according to manufacturer	1 bucket (8 kg)	R2T	3 m ²	12 hours	3 days	Installation with a double layer of adhesive
	LATICRETE	All sizes	LATALASTIK	Not necessary, according to manufacturer	1 bucket of component A (5 kg) 1 bucket of component B (2 kg)	R2T	3 m ²	1 day	7 days	
	LITOKOL	All sizes	LITOELASTIC	Not necessary, according to manufacturer	1 bucket (10 kg)	R2T	3 m ²	12 hours	5 days	
	PCI - BASF	All sizes	PCI NANOLIGHT + PCI LASTOFLEX	Use of the following product is COMPULSORY: PCI GISOGRUN 303	1 bag (15 kg) + 1 can of PCI LASTOFLEX (4 kg) + 5 litres of water	C2 TE S2	5,5 m ²	8 hours	1 day	
	SAINT-GOBAIN / WEBER	All sizes	FIX CR	Not necessary, according to manufacturer	1 bucket (10 kg)	R2	3 m ²	12 hours	2 days	Installation with a single-layer of adhesive (6 mm trowel)
	ARDEX	All sizes	ARDEX X 77 microtec + ARDEX E 90	ARDEX P 82	1 bag (25 kg) + 1 can of ARDEX E 90 (4.5 kg) + 9 litres of water	C2(T) E(E) S2	10 m ²	8 hours	1 day	
 For situations in which a quick setting adhesive is recommended	MAPEI	All sizes	KERAQUICK + LATEX PLUS	Not necessary, according to manufacturer	1 bag (25 kg) + 8.5 kg of LATEX PLUS	C2 FT S2	7 m ²	3 hours	1 day	Installation with a single-layer of adhesive (6 mm trowel)
	KERAKOLL	All sizes	SUPERFLEX ECO	Not necessary, according to manufacturer	1 bucket (8 kg)	R2T	3 m ²	12 hours	3 days	Installation with a double layer of adhesive
	LATICRETE	All sizes	LATALASTIK	Not necessary, according to manufacturer	1 bucket of component A (5 kg) 1 bucket of component B (2 kg)	R2T	3 m ²	1 day	7 days	
	LITOKOL	All sizes	LITOELASTIC	Not necessary, according to manufacturer	1 bucket (10 kg)	R2T	3 m ²	12 hours	5 days	
	PCI - BASF	All sizes	PCI NANOLIGHT + PCI LASTOFLEX	Use of the following product is COMPULSORY: PCI GISOGRUN 303	1 bag (15 kg) + 1 can of PCI LASTOFLEX (4 kg) + 5 litres of water	C2 TE S2	5,5 m ²	8 hours	1 day	
	ARDEX	All sizes	ARDEX X 77 S microtec + ARDEX E 90	ARDEX P 82	1 bag (25 kg) + 3 kg of ARDEX E 90 + 6 litres of water	C2 F(F)T ES2	10 m ²	90 min.	6 hours	Installation with a single-layer of adhesive (6 mm trowel)

(*) Instructions provided directly by manufacturers, who guarantee the information given. For explanations or more details, you can contact the technical support offices of the respective manufacturers (see "9 - handy addresses").
 (**) Instructions provided directly by manufacturers, who guarantee the information given. If a product is offered in both "white" and a "grey" versions, the mixing ratio may vary. For explanations or more details, you can contact the technical support offices of the respective manufacturers (see "9 - handy addresses").
 (****) Ratings provided directly by manufacturers, that guarantee the information given, based on laboratory tests performed at 23° C and with a relative humidity of 50%. For use in different situations, contact the technical support office of the respective manufacturers. For explanations or more details, you can contact the technical support offices of the respective manufacturers (see "9 - handy addresses").

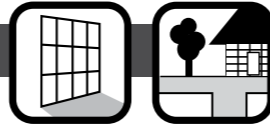
A.3a - Wall installation of KERLITE in exteriors



Supporting material: plaster

At the discretion of I.S.	Manufacturer	Size of slabs (cm)	Product (*)	Primer, if necessary (*)	Mixing ratio (**)	Class (*)	Nominal coverage (*)	Workability (***)	Ready for use (***)	Installation (*)
 For situations in which a normal setting adhesives is recommended	MAPEI	50x50; 100x40; 100x50	KERAFLEX MAXI S1	Not necessary, according to manufacturer	1 bag (25 kg) + 7.2/7.7 litres of water	C2 TE S1	7 m ²	8 hours	14 days	Installation with a double layer of adhesive
			ULTRALITE S1		1 bag (15 kg) + 8.4/8.7 litres of water	C2 TE S1				
		100x100	ULTRALITE S2		1 bag (15 kg) + 5.9/6.2 litres of water	C2 E S2	6,3 m ²			
			KERABOND + ISOLASTIC		1 bag (25 kg) + 8.5 kg of ISOLASTIC	C2 E S2	6,5 m ²			
	KERAKOLL	50x50	H40 Eco flex	Not necessary, according to manufacturer	1 bag (25 kg) + 6.5 litres of water	C2 E	5 m ²	8 hours	7 days	
			H40 Eco tenaflex		1 bag (25 kg) + 8 litres of water	C2 TE				
		100x40; 100x50; 100x100	H40 Eco Extraflex		1 bag (25 kg) + 7.5 litres of water	C2 TE S1				
	LATICRETE	50x50; 100x40; 100x50; 100x100	LATICRETE 254 Platinum	Not necessary, according to manufacturer	1 bag (25 kg) + 6 litres of water	C2 TE S1	5 m ²	1 day	7 days	
	LITOKOL	50x50; 100x40; 100x50	SUPERFLEX K77	Not necessary, according to manufacturer	1 bag (25 kg) + 8.5 litres of water	C2 TE S1	6 m ²	8 hours	7 days	
			CEMENTKOL K21 + LATEXKOL		1 bag (25 kg) + 7.5 kg of LATEXKOL	C2 S2	5 m ²			
	PCI - BASF	50x50; 100x40; 100x50; 100x100	PCI NANOLIGHT	Not necessary, according to manufacturer	1 bag (15 kg) + 9 litres of water	C2 TE S1	5,5 m ²	8 hours	1 day	
	SAINT-GOBAIN / WEBER	50x50; 100x40; 100x50; 100x100	WEBER.COL PRO HP	Not necessary, according to manufacturer	1 bag (25 kg) + 7 litres of water	C2 TE S1	5 m ²	2 days	14 days	
WEBER.COL PRO HF LIGHT			1 bag (15 kg) + 8 litres of water		C2 TE S2	8 hours				
ARDEX	50x50; 100x40; 100x50; 100x100	ARDEX X 77 microtec	Not necessary, according to manufacturer	1 bag (25 kg) + 11 litres of water	C2 T(T) E(E) S1	10 m ²	8 hours	1 day		
 For situations in which a quick setting adhesive is recommended	MAPEI	50x50; 100x40; 100x50	ELASTORAPID	Not necessary, according to manufacturer	Component A: 1 bag (25 kg) Component B: tub (6.5 kg)	C2 FTE S2	6 m ²	3 hours	1 day	Installation with a double layer of adhesive
			ULTRALITE S1 QUICK		1 bag (15 kg) + 5.1/5.7 litres of water	C2 FTE S1				
		100x100	ULTRALITE S2 QUICK		1 bag (15 kg) + 5.1/5.7 litres of water	C2 FE S2	7 m ²			
			KERAQUICK + LATEX PLUS		1 bag (25 kg) + 8.5 kg of LATEX PLUS	C2 FT S2	5 m ²			
	KERAKOLL	50x50	H40 Eco rapid	Not necessary, according to manufacturer	1 bag (25 kg) + 7.3 litres of water	C2 FTE	5 m ²	3 hours	2 days	
		100x40; 100x50; 100x100	H40 Eco Rapidflex		1 bag (25 kg) + 6.3 litres of water	C2 FTE S1	6 m ²			
	LATICRETE	50x50; 100x40; 100x50; 100x100	LATICRETE 335 Rapid Super Flex + LATICRETE 282 Latex Additive	Not necessary, according to manufacturer	1 bag (25 kg) + 6/7 litres of latex	C2 TE F	5 m ²	6 hours	2 days	
	LITOKOL	50x50; 100x40; 100x50	LITOSTONE K99 + LATEXKOL + water	Not necessary, according to manufacturer	1 bag (25 kg) + 3.5 litres of LATEXKOL + 3.5 litres of water	C2 FE S1	5 m ²	4 hours	1 day	
		100x100	LITOSTONE K99 + LATEXKOL		1 bag (25 kg) + 7.5 kg of LATEXKOL	C2 FE S2				
	PCI - BASF	50x50; 100x40; 100x50; 100x100	PCI NANOLIGHT	Not necessary, according to manufacturer	1 bag (15 kg) + 9 litres of water	C2 TE S1	5,5 m ²	8 hours	1 day	
	ARDEX	50x50; 100x40; 100x50; 100x100	ARDEX X 77 S microtec	Not necessary, according to manufacturer	1 bag (25 kg) + 8.5 litres of water	C2 FT(T) E S1	10 m ²	90 min.	6 hours	

(*) Instructions provided directly by manufacturers, who guarantee the information given. For explanations or more details, you can contact the technical support offices of the respective manufacturers (see "9 - handy addresses").



(**) Instructions provided directly by manufacturers, who guarantee the information given. If a product is offered in both "white" and a "grey" versions, the mixing ratio may vary. For explanations or more details, you can contact the technical support offices of the respective manufacturers (see "9 - handy addresses").

(***) Ratings provided directly by manufacturers, that guarantee the information given, based on laboratory tests performed at 23° C and with a relative humidity of 50%. For use in different situations, contact the technical support office of the respective manufacturers. For explanations or more details, you can contact the technical support offices of the respective manufacturers (see "9 - handy addresses").

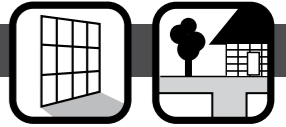
A.3b - Wall installation of KERLITE in exteriors



Supporting material: concrete

At the discretion of I.S.	Manufacturer	Size of slabs (cm)	Product (*)	Primer, if necessary (*)	Mixing ratio (**)	Class (*)	Nominal coverage (*)	Workability (***)	Ready for use (***)	Installation (*)
 For situations in which a normal setting adhesives is recommended	MAPEI	50x50; 100x40; 100x50	KERAFLEX MAXI S1	Not necessary, according to manufacturer	1 bag (25 kg) + 7.2/7.7 litres of water	C2 TE S1	7 m ²	8 hours	14 days	Installation with a double layer of adhesive
			ULTRALITE S1		1 bag (15 kg) + 8.4/8.7 litres of water	C2 TE S1				
		100x100	ULTRALITE S2		1 bag (15 kg) + 5.9/6.2 litres of water	C2 E S2	6,3 m ²			
			KERABOND + ISOLASTIC		1 bag (25 kg) + 8.5 kg of ISOLASTIC	C2 E S2	6,5 m ²			
	KERAKOLL	50x50	H40 Eco flex	Not necessary, according to manufacturer	1 bag (25 kg) + 6.5 litres of water	C2 E	5 m ²	8 hours	7 days	
			H40 Eco tenaflex		1 bag (25 kg) + 8 litres of water	C2 TE				
		100x40; 100x50; 100x100	H40 Eco Extraflex		1 bag (25 kg) + 7.5 litres of water	C2 TE S1				
	LATICRETE	50x50; 100x40; 100x50; 100x100	LATICRETE 254 Platinum	Not necessary, according to manufacturer	1 bag (25 kg) + 6 litres of water	C2 TE S1	5 m ²	1 day	7 days	
	LITOKOL	50x50; 100x40; 100x50	SUPERFLEX K77	Not necessary, according to manufacturer	1 bag (25 kg) + 8.5 litres of water	C2 TE S1	6 m ²	8 hours	7 days	
			CEMENTKOL K21 + LATEXKOL		1 bag (25 kg) + 7.5 kg of LATEXKOL	C2 S2	5 m ²			
	PCI - BASF	50x50; 100x40; 100x50; 100x100	PCI NANOLIGHT	Not necessary, according to manufacturer	1 bag (15 kg) + 9 litres of water	C2 TE S1	5,5 m ²	8 hours	1 day	
	SAINT-GOBAIN / WEBER	50x50; 100x40; 100x50; 100x100	WEBER.COL PRO HP	Not necessary, according to manufacturer	1 bag (25 kg) + 7 litres of water	C2 TE S1	5 m ²	2 days	14 days	
WEBER.COL PRO HF LIGHT			1 bag (15 kg) + 8 litres of water		C2 TE S2	8 hours				
ARDEX	50x50; 100x40; 100x50; 100x100	ARDEX X 77 microtec	Not necessary, according to manufacturer	1 bag (25 kg) + 11 litres of water	C2 T(T) E(E) S1	10 m ²	8 hours	1 day		
 For situations in which a quick setting adhesive is recommended	MAPEI	50x50; 100x40; 100x50	ELASTORAPID	Not necessary, according to manufacturer	Component A: 1 bag (25 kg) Component B: tub (6.5 kg)	C2 FTE S2	6 m ²	3 hours	1 day	Installation with a double layer of adhesive
			ULTRALITE S1 QUICK		1 bag (15 kg) + 5.1/5.7 litres of water	C2 FTE S1				
		100x100	ULTRALITE S2 QUICK		1 bag (15 kg) + 5.1/5.7 litres of water	C2 FE S2	7 m ²			
			KERAQUICK + LATEX PLUS		1 bag (25 kg) + 8.5 kg of LATEX PLUS	C2 FT S2	5 m ²			
	KERAKOLL	50x50	H40 Eco rapid	Not necessary, according to manufacturer	1 bag (25 kg) + 7.3 litres of water	C2 FTE	5 m ²	3 hours	2 days	
		100x40; 100x50; 100x100	H40 Eco Rapidflex		1 bag (25 kg) + 6.3 litres of water	C2 FTE S1	6 m ²			
	LATICRETE	50x50; 100x40; 100x50; 100x100	LATICRETE 335 Rapid Super Flex + LATICRETE 282 Latex Additive	Not necessary, according to manufacturer	1 bag (25 kg) + 6/7 litres of latex	C2 TE F	5 m ²	6 hours	2 days	
	LITOKOL	50x50; 100x40; 100x50	LITOSTONE K99 + LATEXKOL + water	Not necessary, according to manufacturer	1 bag (25 kg) + 3.5 litres of LATEXKOL + 3.5 litres of water	C2 FE S1	5 m ²	4 hours	1 day	
		100x100	LITOSTONE K99 + LATEXKOL		1 bag (25 kg) + 7.5 kg of LATEXKOL	C2 FE S2				
	PCI - BASF	50x50; 100x40; 100x50; 100x100	PCI NANOLIGHT	Not necessary, according to manufacturer	1 bag (15 kg) + 9 litres of water	C2 TE S1	5,5 m ²	8 hours	1 day	
	ARDEX	50x50; 100x40; 100x50; 100x100	ARDEX X 77 S microtec	Not necessary, according to manufacturer	1 bag (25 kg) + 8.5 litres of water	C2 FT(T) E S1	10 m ²	90 min.	6 hours	

(*) Instructions provided directly by manufacturers, who guarantee the information given. For explanations or more details, you can contact the technical support offices of the respective manufacturers (see "9 - handy addresses").



(**) Instructions provided directly by manufacturers, who guarantee the information given. If a product is offered in both "white" and a "grey" versions, the mixing ratio may vary. For explanations or more details, you can contact the technical support offices of the respective manufacturers (see "9 - handy addresses").

(***) Ratings provided directly by manufacturers, that guarantee the information given, based on laboratory tests performed at 23° C and with a relative humidity of 50%. For use in different situations, contact the technical support office of the respective manufacturers. For explanations or more details, you can contact the technical support offices of the respective manufacturers (see "9 - handy addresses").

A.4a - Wall installation of KERLITE PLUS in exteriors



Supporting material: plaster

At the discretion of I.S.	Manufacturer	Size of slabs (cm)	Product (*)	Primer, if necessary (*)	Mixing ratio (**)	Class (*)	Nominal coverage (*)	Workability (***)	Ready for use (***)	Installation (*)
 For situations in which a normal setting adhesive is recommended	MAPEI	50x50; 100x40; 100x50	KERABOND + ISOLASTIC	Not necessary, according to manufacturer	1 bag (25 kg) + 8.5 kg of ISOLASTIC	C2 E S2	5 m ²	8 hours	14 days	Installation with a double layer of adhesive
			ULTRALITE S2		1 bag (15 kg) + 5.9/6.2 litres of water	C2 E S2	3 m ²			
		100x100; 300x100	KERALASTIC T		1 can (10 kg)	R2T	2,5 m ²	12 hours	7 days	
	KERAKOLL	50x50	H40 Eco flex	Not necessary, according to manufacturer	1 bag (25 kg) + 6.5 litres of water	C2 E	5 m ²	approx. 8 hours	7 days	
			H40 Eco tenaflex		1 bag (25 kg) + 8 litres of water	C2 TE				
			100x40; 100x50; 100x100; 300x100		H40 Eco Extraflex	1 bag (25 kg) + 7.5 litres of water	C2 TE S1			
	LATICRETE	All sizes	LATICRETE 254 Platinum	Not necessary, according to manufacturer	1 bag (25 kg) + 6 litres of water	C2 TE S1	5 m ²	1 day	7 days	
	LITOKOL	All sizes	CEMENTKOL K21 + LATEXKOL	Not necessary, according to manufacturer	1 bag (25 kg) + 7.5 kg of LATEXKOL	C2 S2	5 m ²	8 hours	7 days	
	PCI - BASF	All sizes	PCI NANOLIGHT + PCI LASTOFLEX	Not necessary, according to manufacturer	1 bag (15 kg) + 1 can of PCI LASTOFLEX (4 kg) + 5 litres of water	C2 TE S2	5,5 m ²	8 hours	1 day	
	SAINT-GOBAIN / WEBER	All sizes	WEBER.COL PRO HP	Not necessary, according to manufacturer	1 bag (25 kg) + 7 litres of water	C2 TE S1	5 m ²	2 days	14 days	
WEBER.COL PRO HF LIGHT			1 bag (15 kg) + 8 litres of water		C2 TE S2	8 hours				
ARDEX	All sizes	ARDEX X 77 microtec + ARDEX E 90	Not necessary, according to manufacturer	1 bag (25 kg) + 1 can of ARDEX E 90 (4.5 kg) + 9 litres of water	C2 T(T) E(E) S2	10 m ²	8 hours	1 day		
 For situations in which a quick setting adhesive is recommended	MAPEI	50x50; 100x40; 100x50	ULTRALITE S2 QUICK	Not necessary, according to manufacturer	1 bag (15 kg) + 6 litres of water	C2 FE S2	4 m ²	3 hours	2 days	Installation with a double layer of adhesive
			100x100; 300x100		KERAQUICK + LATEX PLUS	1 bag (25 kg) + 8.5 kg of LATEX PLUS	C2 FT S2		5 m ²	
	KERAKOLL	50x50	H40 Eco rapid	Not necessary, according to manufacturer	1 bag (25 kg) + 7.3 litres of water	C2 F TE	6 m ²	3 hours	2 days	
			100x40; 100x50; 100x100; 300x100		H40 Eco Rapidflex	1 bag (25 kg) + 6.3 litres of water				
	LATICRETE	All sizes	LATICRETE 335 Rapid Super Flex + LATICRETE 282 Latex Additive	Not necessary, according to manufacturer	1 bag (25 kg) + 6/7 litres of latex	C2 TE F	5 m ²	6 hours	2 days	
	LITOKOL	All sizes	LITOSTONE K99 + LATEXKOL	Not necessary, according to manufacturer	1 bag (25 kg) + 7.5 kg of LATEXKOL	C2 FE S2	5 m ²	4 hours	1 day	
	PCI - BASF	All sizes	PCI NANOLIGHT + PCI LASTOFLEX	Not necessary, according to manufacturer	1 bag (15 kg) + 1 can of PCI LASTOFLEX (4 kg) + 5 litres of water	C2 TE S2	5,5 m ²	8 hours	1 day	
ARDEX	All sizes	ARDEX X 77 S microtec + ARDEX E 90	Not necessary, according to manufacturer	1 bag (25 kg) + 3 kg of ARDEX E 90 + 6 litres of water	C2 FT(T) E S2	10 m ²	90 min.	6 hours		

(*) Instructions provided directly by manufacturers, who guarantee the information given. For explanations or more details, you can contact the technical support offices of the respective manufacturers (see "9 - handy addresses").



(**) Instructions provided directly by manufacturers, who guarantee the information given. If a product is offered in both "white" and a "grey" versions, the mixing ratio may vary. For explanations or more details, you can contact the technical support offices of the respective manufacturers (see "9 - handy addresses").

(***) Ratings provided directly by manufacturers, that guarantee the information given, based on laboratory tests performed at 23° C and with a relative humidity of 50%. For use in different situations, contact the technical support office of the respective manufacturers. For explanations or more details, you can contact the technical support offices of the respective manufacturers (see "9 - handy addresses").

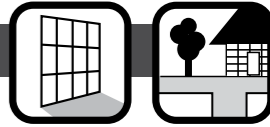
A.4b - Wall installation of KERLITE PLUS in exteriors



Supporting material: concrete

At the discretion of I.S.	Manufacturer	Size of slabs (cm)	Product (*)	Primer, if necessary (*)	Mixing ratio (**)	Class (*)	Nominal coverage (*)	Workability (***)	Ready for use (***)	Installation (*)
 For situations in which a normal setting adhesive is recommended	MAPEI	50x50; 100x40; 100x50	KERABOND + ISOLASTIC	Not necessary, according to manufacturer	1 bag (25 kg) + 8.5 kg of ISOLASTIC	C2 E S2	5 m ²	8 hours	14 days	Installation with a double layer of adhesive
			ULTRALITE S2		1 bag (15 kg) + 5.9/6.2 litres of water	C2 E S2	3 m ²			
		100x100; 300x100	KERALASTIC T		1 can (10 kg)	R2T	2,5 m ²	12 hours	7 days	
	KERAKOLL	50x50	H40 Eco flex	Not necessary, according to manufacturer	1 bag (25 kg) + 6.5 litres of water	C2 E	5 m ²	8 hours	7 days	
			H40 Eco tenaflex		1 bag (25 kg) + 8 litres of water	C2 TE				
			100x40; 100x50; 100x100; 300x100		H40 Eco Extraflex	1 bag (25 kg) + 7.5 litres of water	C2 TE S1			
	LATICRETE	All sizes	LATICRETE 254 Platinum	Not necessary, according to manufacturer	1 bag (25 kg) + 6 litres of water	C2 TE S1	5 m ²	1 day	7 days	
	LITOKOL	All sizes	CEMENTKOL K21 + LATEXKOL	Not necessary, according to manufacturer	1 bag (25 kg) + 7.5 kg of LATEXKOL	C2 S2	5 m ²	8 hours	7 days	
	PCI - BASF	All sizes	PCI NANOLIGHT + PCI LASTOFLEX	Not necessary, according to manufacturer	1 bag (15 kg) + 1 can of PCI LASTOFLEX (4 kg) + 6 litres of water	C2 TE S2	5,5 m ²	8 hours	1 day	
	SAINT-GOBAIN / WEBER	All sizes	WEBER.COL PRO HP	Not necessary, according to manufacturer	1 bag (25 kg) + 7 litres of water	C2 TE S1	5 m ²	2 days	14 days	
WEBER.COL PRO HF LIGHT			1 bag (15 kg) + 8 litres of water		C2 TE S2	8 hours				
ARDEX	All sizes	ARDEX X 77 microtec + ARDEX E 90	Not necessary, according to manufacturer	1 bag (25 kg) + 1 can of ARDEX E 90 (4.5 kg) + 9 litres of water	C2 T(T) E(E) S2	10 m ²	8 hours	1 day		
 For situations in which a quick setting adhesive is recommended	MAPEI	50x50; 100x40; 100x50	ULTRALITE S2 QUICK	Not necessary, according to manufacturer	1 bag (15 kg) + 6 litres of water	C2 FE S2	4 m ²	3 hours	2 days	Installation with a double layer of adhesive
			100x100; 300x100		KERAQUICK + LATEX PLUS	1 bag (25 kg) + 8.5 kg of LATEX PLUS	C2 FT S2		5 m ²	
	KERAKOLL	50x50	H40 Eco rapid	Not necessary, according to manufacturer	1 bag (25 kg) + 7.3 litres of water	C2 F TE	6 m ²	3 hours	2 days	
			100x40; 100x50; 100x100; 300x100		H40 Eco Rapidflex	1 bag (25 kg) + 6.3 litres of water				
	LATICRETE	All sizes	LATICRETE 335 Rapid Super Flex + LATICRETE 282 Latex Additive	Not necessary, according to manufacturer	1 bag (25 kg) + 6/7 litres of latex	C2 TE F	5 m ²	6 hours	2 days	
	LITOKOL	All sizes	LITOSTONE K99 + LATEXKOL	Not necessary, according to manufacturer	1 bag (25 kg) + 7.5 kg of LATEXKOL	C2 FE S2	5 m ²	4 hours	1 day	
	PCI - BASF	All sizes	PCI NANOLIGHT + PCI LASTOFLEX	Not necessary, according to manufacturer	1 bag (15 kg) + 1 can of PCI LASTOFLEX (4 kg) + 6 litres of water	C2 TE S2	5,5 m ²	8 hours	1 day	
ARDEX	All sizes	ARDEX X 77 S microtec + ARDEX E 90	Not necessary, according to manufacturer	1 bag (25 kg) + 3 kg of ARDEX E 90 + 6 litres of water	C2 FT(T) E S2	10 m ²	90 min.	6 hours		

(*) Instructions provided directly by manufacturers, who guarantee the information given. For explanations or more details, you can contact the technical support offices of the respective manufacturers (see "9 - handy addresses").



(**) Instructions provided directly by manufacturers, who guarantee the information given. If a product is offered in both "white" and a "grey" versions, the mixing ratio may vary. For explanations or more details, you can contact the technical support offices of the respective manufacturers (see "9 - handy addresses").

(***) Ratings provided directly by manufacturers, that guarantee the information given, based on laboratory tests performed at 23° C and with a relative humidity of 50%. For use in different situations, contact the technical support office of the respective manufacturers. For explanations or more details, you can contact the technical support offices of the respective manufacturers (see "9 - handy addresses").

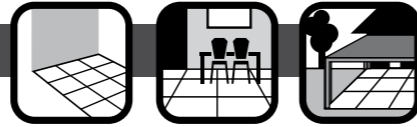
A.5a - Wall installation in interiors/exterior* of KERLITE PLUS





Supporting material: cement-based screeds, calcium sulphate-based or heated screeds, self-levelling products, concrete, old ceramic tile, marble slabs, stone

At the discretion of I.S.	Manufacturer	Size of slabs (cm)	Product (*)	Primer, if necessary (*)	Mixing ratio (**)	Class (*)	Nominal coverage (*)	Setting for foot traffic and workability (***)	Ready for use (****)	Installation (*)
 For situations in which a normal setting adhesives is recommended	MAPEI	50x50;100x40; 100x50	KERAFLEX MAXI S1	COMPULSORY for gypsum-based, anhydride or absorbent surfaces: Primer G or ECOPRIM T For non-absorbent supports: ECOPRIM GRIP	1 bag (25 kg) + 7.2/7.7 litres of water	C2 TE S1	3,5 m ²	1 day	14 days	Installation with a double layer of adhesive
			ULTRALITE S1		1 bag (15 kg) + 8.4/8.7 litres of water	C2 TE S1		8 hours		
		100x100; 300x100	ULTRALITE S2		1 bag (15 kg) + 5.9/6.2 litres of water	C2 E S2	5 m ²	1 day		
			KERABOND + ISOLASTIC		1 bag (25 kg) + 8.5 kg of ISOLASTIC	C2 E S2				
		For heated screeds: All sizes	KERABOND + ISOLASTIC		1 bag (25 kg) + 8.5 kg of ISOLASTIC	C2 E S2	3,5 m ²	1 day		
			ULTRALITE S2		1 bag (15 kg) + 5.9/6.2 litres of water	C2 E S2				
	KERAKOLL	All sizes	H40 Eco flex	For gypsum-based surfaces: Primer A Eco	1 bag (25 kg) + 6.5 litres of water	C2 E	5 m ²	1 day	7 days	
	LATICRETE	All sizes	LATICRETE 254 Platinum	Not necessary, according to manufacturer	1 bag (25 kg) + 6 litres of water	C2 TE S1	5 m ²	1 day	7 days	
	LITOKOL	50x50;100x40; 100x50	SUPERFLEX K77	For anhydrite screeds: Primer C	1 bag (25 kg) + 8.5 litres of water	C2 TE S1	5 m ²	8 hours	7 days	
			CEMENTKOL K21 + LATEXKOL		1 bag (25 kg) + 7.5 kg of LATEXKOL	C2 S2				
	PCI - BASF	All sizes	PCI NANOLIGHT + PCI LASTOFLEX	If support is anhydrite-based: PCI GISOGRUND On old, non-absorbent floors: PCI GISOGRUND 303	1 bag (15 kg) + 1 can of PCI LASTOFLEX (4 kg) + 5 litres of water	C2 TE S2	5,5 m ²	8 hours	1 day	
					1 bag (25 kg) + 7 litres of water	C2 TE S1				
SAINT-GOBAIN / WEBER	All sizes	WEBER.COL PRO HP	For anhydrite- or calcium sulphate-based surfaces: WEBER.PRIM PF15	1 bag (15 kg) + 8 litres of water	C2 TE S2	5 m ²	2 days	14 days		
				1 bag (15 kg) + 7 litres of water	C2 TE S1					
ARDEX	All sizes	ARDEX X 78 microtec + ARDEX E 90	For gypsum- and anhydrite-based, absorbent or polished surfaces: ARDEX P 51	1 bag (25 kg) + 1 can of ARDEX E 90 (4.5 kg) + 9 litres of water	C2 E(E) S2	6 m ²	8 hours	1 day		
 For situations in which a quick setting adhesive is recommended	MAPEI	50x50;100x40; 100x50	GRANIRAPID	COMPULSORY for gypsum-based, anhydride or absorbent surfaces: Primer G or ECOPRIM T For non-absorbent supports: ECOPRIM GRIP	Component A: 1 bag (25 kg) Component B: tub (5.5 kg)	C2 F S1	4 m ²	3 hours	1 day	Installation with a double layer of adhesive
			ULTRALITE S1 QUICK		1 bag (15 kg) + 5.1/5.7 litres of water	C2 FTE S1	3,5 m ²			
		100x100; 300x100	ULTRALITE S2 QUICK		1 bag (15 kg) + 5.1/5.7 litres of water	C2 FE S2	4 m ²			
			ELASTORAPID		Component A: 1 bag (25 kg) Component B: tub (6.5 kg)	C2 FTE S2				
		For heated screeds: 50x50;100x40; 100x50	ELASTORAPID		Component A: 1 bag (25 kg) Component B: tub (6.5 kg)	C2 FTE S2	5 m ²			
	For heated screeds: 100x100; 300x100	KERAQUICK + LATEX PLUS	1 bag (25 kg) + 8.5 kg of LATEX PLUS	C2 FT S2	5 m ²					
	KERAKOLL	All sizes	H40 Eco rapid	For gypsum-based surfaces: Primer A Eco	1 bag (25 kg) + 7.3 litres of water	C2 FE	6 m ²	3 hours	2 days	
	LATICRETE	All sizes	LATICRETE 335 Rapid Super Flex + LATICRETE 282 Latex Additive	Not necessary, according to manufacturer	1 bag (25 kg) + 6/7 litres of latex	C2 TE F	5 m ²	6 hours	2 days	
	LITOKOL	50x50; 100x40; 100x50	LITOSTONE K99 + LATEXKOL + water	For gypsum-based surfaces: Primer C	1 bag (25 kg) + 3.5 litres of LATEXKOL + 3.5 litres of water	C2 FE S1	5 m ²	4 hours	1 day	
					1 bag (25 kg) + 7.5 kg of LATEXKOL	C2 FE S2				
		For heated screeds: All sizes	LITOSTONE K99 + LATEXKOL		1 bag (25 kg) + 7.5 kg of LATEXKOL	C2 FE S2				
	PCI - BASF	All sizes	PCI NANOLIGHT + PCI LASTOFLEX	If support is anhydrite-based: PCI GISOGRUND On old, non-absorbent floors: PCI GISOGRUND 303	1 bag (15 kg) + 1 can of PCI LASTOFLEX (4 kg) + 5 litres of water	C2 TE S2	5,5 m ²	8 hours	1 day	
ARDEX	All sizes	ARDEX X 78 S microtec + ARDEX E 90	For gypsum- and anhydrite-based, absorbent or polished surfaces: ARDEX P 51	1 bag (25 kg) + 3 kg of ARDEX E 90 + 6 litres of water	C2 FE S2	6 m ²	90 min.	6 hours		

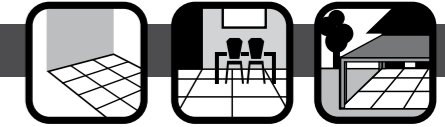
A.5b - Floor installation in interiors/exterior* of KERLITE PLUS



Supporting material: wood, PVC, rubber, linoleum, metal, resin

At the discretion of I.S.	Manufacturer	Size of slabs (cm)	Product (*)	Primer, if necessary (*)	Mixing ratio (**)	Class (*)	Nominal coverage (*)	Setting for foot traffic and workability (***)	Ready for use (****)	Installation (*)
 For situations in which a normal setting adhesives is recommended	MAPEI	All sizes	KERALASTIC	Not necessary, according to manufacturer	1 can (10 kg)	R2	2,5 m ²	12 hours	7 days	Installation with a double layer of adhesive
			KERALASTIC T			R2T				
	KERAKOLL	All sizes	SUPERFLEX ECO	Not necessary, according to manufacturer	1 bucket (8 kg)	R2T	3 m ²	1 day	3 days	
	LATICRETE	All sizes	LATALASTIK	Not necessary, according to manufacturer	1 bucket of component A (5 kg) 1 bucket of component B (2 kg)	R2T	3 m ²	1 day	5 days	
	LITOKOL	All sizes	LITOELASTIC	Not necessary, according to manufacturer	1 bucket (10 kg)	R2T	3 m ²	12 hours	5 days	
	PCI - BASF	All sizes	PCI COLLASTIC	Not necessary, according to manufacturer	3 kg bucket (A+B)	R2T	1.5 m ²	12 hours	1 day	
	SAINT-GOBAIN / WEBER	All sizes	FIX CR	Not necessary, according to manufacturer	1 bucket (10 kg)	R2	4 m ²	12 hours	2 days	
	ARDEX	All sizes	ARDEX X 78 microtec + ARDEX E 90	ARDEX P 82	1 bag (25 kg) + 1 can of ARDEX E 90 (4.5 kg) + 9 litres of water	C2 E(E) S2	6 m ²	8 hours	1 day	
 For situations in which a quick setting adhesive is recommended	MAPEI	All sizes	KERAQUICK + LATEX PLUS	Not necessary, according to manufacturer	1 bag (25 kg) + 8.5 kg of LATEX PLUS	C2 FT S2	2,5 m ²	3 hours	1 day	Installation with a double layer of adhesive
	KERAKOLL	All sizes	SUPERFLEX ECO	Not necessary, according to manufacturer	1 bucket (8 kg)	R2T	3 m ²	1 day	3 days	
	LATICRETE	All sizes	LATALASTIK	Not necessary, according to manufacturer	1 bucket of component A (5 kg) 1 bucket of component B (2 kg)	R2T	3 m ²	1 day	5 days	
	LITOKOL	All sizes	LITOELASTIC	Not necessary, according to manufacturer	1 bucket (10 kg)	R2T	3 m ²	12 hours	7 days	
	PCI - BASF	All sizes	PCI COLLASTIC	Not necessary, according to manufacturer	3 kg bucket (A+B)	R2T	1.5 m ²	3 hours	12 hours	
	ARDEX	All sizes	ARDEX X 78 S microtec + ARDEX E 90	ARDEX P 82	1 bag (25 kg) + 3 kg of ARDEX E 90 + 6 litres of water	C2 FE S2	6 m ²	90 min.	6 hours	

(*) Upon condition that surfaces are sheltered (e.g. loggias, covered balconies, etc.) and made totally impervious.

(*) Instructions provided directly by manufacturers, who guarantee the information given. For explanations or more details, you can contact the technical support offices of the respective manufacturers (see "9 - handy addresses").

(**) Instructions provided directly by manufacturers, who guarantee the information given. If a product is offered in both "white" and a "grey" versions, the mixing ratio may vary. For explanations or more details, you can contact the technical support offices of the respective manufacturers (see "9 - handy addresses").

(****) Ratings provided directly by manufacturers, that guarantee the information given, based on laboratory tests performed at 23° C and with a relative humidity of 50%. For use in different situations, contact the technical support office of the respective manufacturers. For explanations or more details, you can contact the technical support offices of the respective manufacturers (see "9 - handy addresses").

Follow us on:



Quality management system.



Environmental management systems of production sites.



FIORANO (MO)

Panariagroup Industrie Ceramiche S.p.A. is a member of the U.S. Green Building Council and Green Building Council Italia.



PARTNER CASACLIMA.

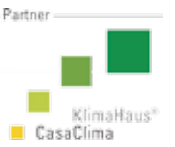

IMPORTANT

The information and directions provided in this manual are to be considered valid until an update is published. The updated document replaces all previous publications. You can check for updates on our web site or contact the company's technical support office. The company reserves the right to modify the contents and appearance of this manual, should this be deemed necessary.

kerlite[®]
Technical manual

COTTO D'ESTE[®]
Nuove Superfici

Via Emilia Romagna, 31 - 41049 Sassuolo (MO) Italy
tel. +39 0536 814 911 fax +39 0536 814 918 email info@cottodeste.it
cottodeste.it - kerlite.it